

# OPERATION, MAINTENANCE AND INSTALLATION MANUAL

FOR PC-500/PC-500W PRECRUSHER COMPACTOR

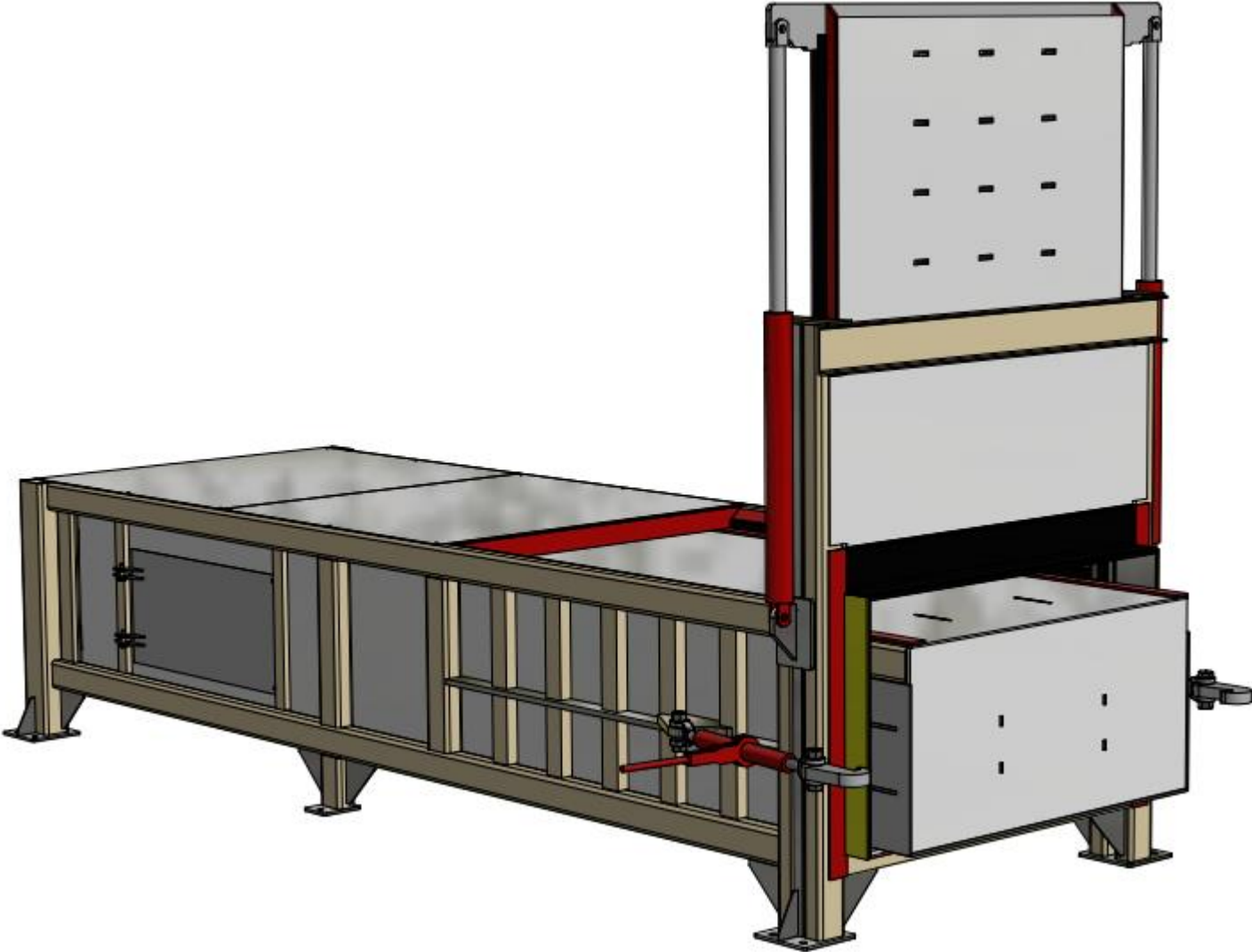

INTERNATIONAL CONTAINER  
COMPACTION UNITS  
MANUFACTURED BY: INTERNATIONAL CONTAINER CO., LLC  
110 NORTH BRIDGE ST., HOLYOKE, MA 01040 12/4/2024

## **TABLE OF CONTENTS**

1-INTRODUCTION

2- GENERAL SPECIFICATIONS

3- SPECIFICATIONS

### **OPERATION SECTION**

4- DECALS

5- DECAL PART NUMBERS

6- DECAL PLACEMENT

7- SAFETY ORIENTATION

8- OWNER/EMPLOYER RESPONSIBILITIES

9- OPERATOR/EMPLOYEE RESPONSIBILITIES

9- HAZARDOUS ENERGY CONTROL

10- HAZARDOUS ENERGY CONTROL

10- ARC FLASHSAFETY

10- SAFETY AND TRAINING PROGRAM

11- GENERAL TRAINING

### **MAITENANCE**

12- LOCK OUT/TAG OUT INSTRUCTIONS

13- HYDRAULIC SAFETY

14- PREVENTATIVE MAINTENANCE

15- TROUBLE SHOOTING

### **INSTALLATION**

16- CONCRETE PAD

16- POSITIONING/ANCHORING

17- ELECTRICAL/HYDRAULIC INSTALLATION

18- STARTUP INSTRUCTIONS

19- LEGAL PROVISIONS

**CAUTION:** Review and understand the power unit manual included with this compactor.

**CAUTION:** Review this manual before making the installation. Study the jobsite and the installation requirements carefully to be certain all necessary safeguards and/or safety devices are provided to protect all personnel and equipment during installation and as a complete system. Special attention is directed to the most current extract from American National Standards Institute Z245.2. These instructions are not intended as a substitute for proper training and experience in proper use and safety procedures in operating this equipment. International Container Co. does not assume responsibility for the installation procedures of this equipment. Conformance to local, state, and federal laws concerning installation rests with the customer.

## 1-INTRODUCTION

### THANK YOU FOR PURCHASING AN INTERNATIONAL CONTAINER PRECRUSHER COMPACTOR

This compactor is designed to give you reliable and superior performance for many years to come. The purpose of this manual is to provide the owner(s) and/or operator(s) with the necessary information to properly install, operate, and maintain your stationary compactor. This manual **IS NOT** intended as a primary training source, but as a reference guide for authorized, trained personnel. Each person involved in the operation, maintenance, and installation of the machine should read and thoroughly understand the instructions in this manual and follow **ALL** warnings prior to operation.

The owner(s) and/or employer(s) involved in the operation, maintenance, and installation of this compactor should always read and understand the most current version of the following applicable standards:

ANSI-Z245.2

“STATIONARY COMPACTOR REQUIREMENTS”

A copy of this standard may be  
obtained from: ANSI  
25 West 43<sup>rd</sup> Street  
New York, New York 10036

OSHA 29 CFR, Part 1910.147

“The control of hazardous energy (lock-out/tag-out)”

---

Employer(s)/Equipment owners are responsible for the safe installation, training, and operation of this equipment. Final installation requirements must be met by the installer. Employer(s)/Equipment owners are responsible for establishing and implementing a lock-out/tag-out procedure. This manual serves only a guideline for these procedures.

Any service or repairs recommended by this manual should be performed by factory authorized personnel only.

If you need assistance with your compactor, please contact

International Container Co., LLC. When contacting, you will need to provide the compactor serial number, installation date, and power unit serial number.

If you have any safety concerns with the equipment, or need further information, please contact us at:

INTERNATIONAL CONTAINER CO., LLC  
110 N. Bridge St., Holyoke, MA 01040  
413-538-9200  
office@internationalcontainerco.com

In addition to this operation, maintenance, installation manual, an additional instructional manual is provided with each power unit. Please read all comprehensive instructions and information in both manuals prior to operation, maintenance, or installation. THIS MACHINE IS INHERENTLY DANGEROUS AND FAILURE TO FOLLOW THE INSTRUCTIONS CONTAINED IN THESE MANUALS MAY RESULT IN SERIOUS INJURY OR DEATH!



# WARNING

**IF INCORRECTLY USED, THIS EQUIPMENT CAN CAUSE SEVERE INJURY. THOSE WHO USE AND MAINTAIN THE EQUIPMENT SHOULD BE TRAINED IN ITS PROPER USE, WARNED OF ITS DANGERS, AND SHOULD READ AND FULLY UNDERSTAND THIS ENTIRE MANUAL BEFORE ATTEMPTING TO SET UP, OPERATE, ADJUST OR SERVICE THE EQUIPMENT. KEEP THIS MANUAL FOR FUTURE REFERENCE**

**2-GENERAL SPECIFICATIONS**

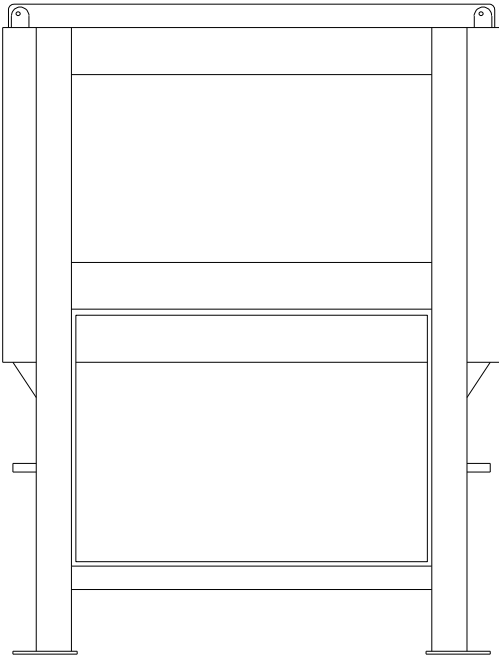
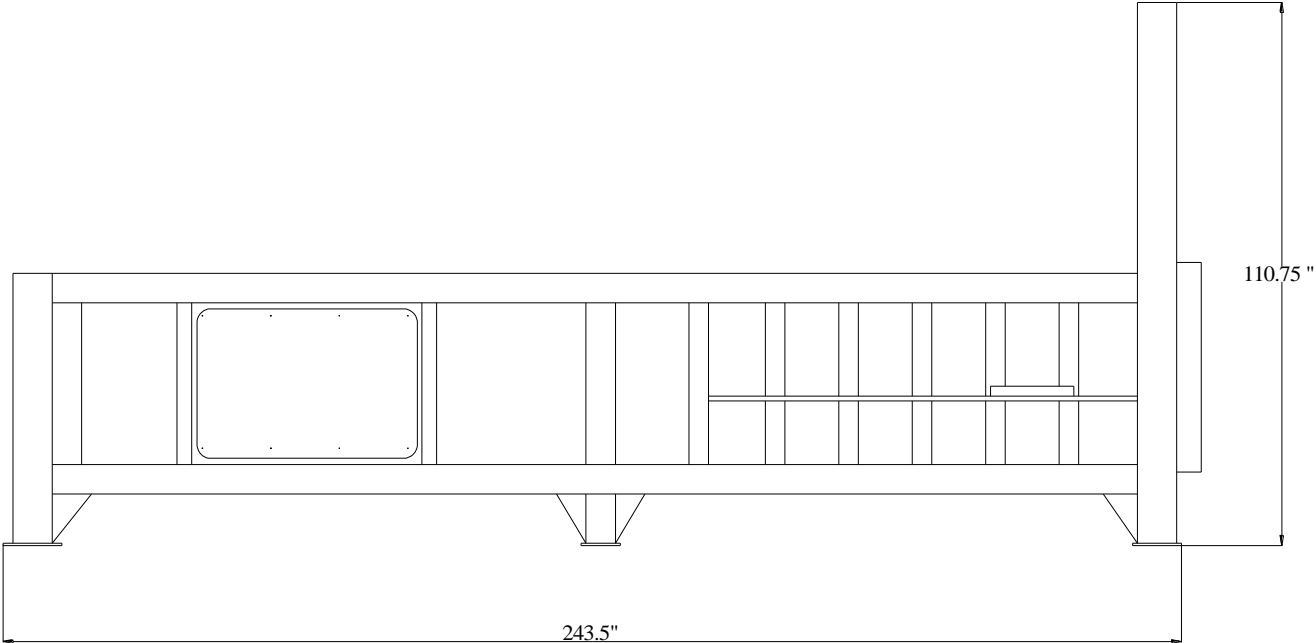

**MACHINE WIDTH**

PC-500	85"
PC-500W	97"

### 3-SPECIFICATIONS

	PC-500	PC-500W
-CLEAR TOP OPENING:	60" X 88.5"	72" X 88.5"
-DISCHARGE OPENING:	41.5"X 60"	41.5" X 72"
-LOAD HEIGHT-	55"	55"
-*CYCLE TIME(SEC):		
-PRECRUSHER MODE:		
-COMPACTOR MODE:		
-*RAM RELIEF PRESSURE:	2400 PSI	2400 PSI
-*GATE RELIEF PRESSURE:	1900 PSI	1900 PSI
- MOTOR HP:	30	30
-*PUMP CAPACITY(GPM):	44/18	44/18
-*RESERVOIR CAPACITY(GAL):	60	60
- HYDRAULIC CYLINDER:		
BORE:	7"	7"
ROD:	4"	4"
STROKE:	112"	112"
-RAM PENETRATION:	14.5"	14.5"
-RAM FORCE (LBS):		
-NORMAL:	80,800	80,800
-MAXIMUM:	84,660	84,660
-GUIDES: ADJUSTABLE UHMW		
-UNIT WEIGHT (LBS):	19,700	22,000

\*- Varies depending on power unit manufacturer, and model of power unit. Please consult the manual provided in power unit of this compactor.

**NOTE:** Cycle times may vary due to power unit size, manufacturer, voltage, etc. Actual cycle time settings must be adjusted at the time of installation.

# 4-COMPACTOR OPERATION DECALS



ICCLBL1000



CWL1000



SCC-001



SCC-002



SCC-003



SCC-004



SCC-005



SCC-006



SCC-007



SCC-008



SCC-011



SCC-012



SCC-013



SCC-014



SCC-015

## **5-COMPACTOR OPERATION DECAL PART NUMBER**

### **DECAL PART NUMBERS**

When your compactor leaves the factory several WARNING DECALS are installed for your protection. These labels are subject to wear due to the nature of the operation. THE FOLLOWING DECALS MUST BE MAINTAINED. Additional decals maybe purchased through INTERNATIONAL CONTAINER CO. by calling 413-538-9200. When ordering replacement decals, match the part numbers in the chart below to the drawings on the previous page.

<b>PART NUMBER</b>	<b>DESCRIPTION</b>
ICCLBL-010	INTERNATIONAL CONTAINER CO.
CWL1000	WARNING/ CAUTION
SCC-001	WARNING STAND CLEAR OF COMPACTOR
SCC-002	CONFINED SPACE
SCC-003	WARNING DO NOT REMOVE ACCESS COVERS
SCC-004	DO NOT REMOVE CONTAINER UNTIL REAR STOPS...
SCC-005	CAUTION WIPE OFF SEAL AFTER DUMPING
SCC-006	NOTICE FEDERAL REGULATION<NO 18 YEARS OLD
SCC-007	FIRE HOSE PORT
SCC-008	DANGER HAZARDOUS VOLTAGE
SCC-011	DANGER VOLTS
SCC-012	CAUTION DISCONNECT HOSES
SCC-013	WARNING KEEP OUT CRUSH/SHEAR HAZARD
SCC-014	WARNING CRUSH/SHEAR CLOSE GATE
SCC-015	CAUTION COMPACTOR STARTS AUTOMATICALLY

**QUANTITIES VARY DEPENDING ON EQUIPMENT AND OPTIONS.  
SOME DECALS MAY BE INSTALLED ON THE POWER UNIT**



# 6-COMPACTOR OPERATION DECAL PLACEMENT ON COMPACTOR

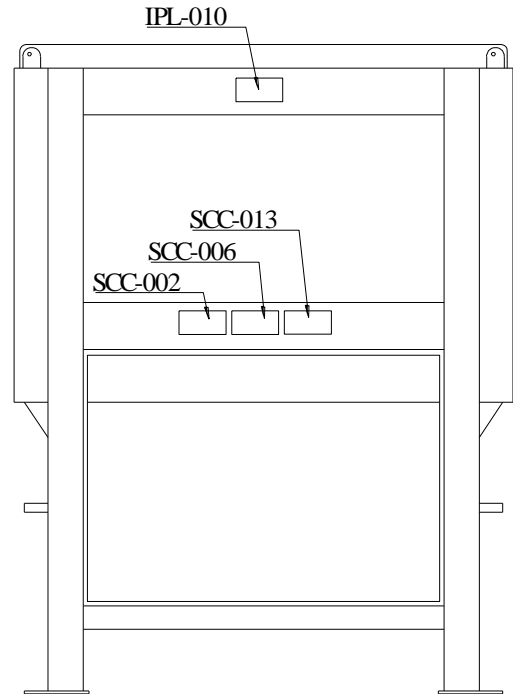
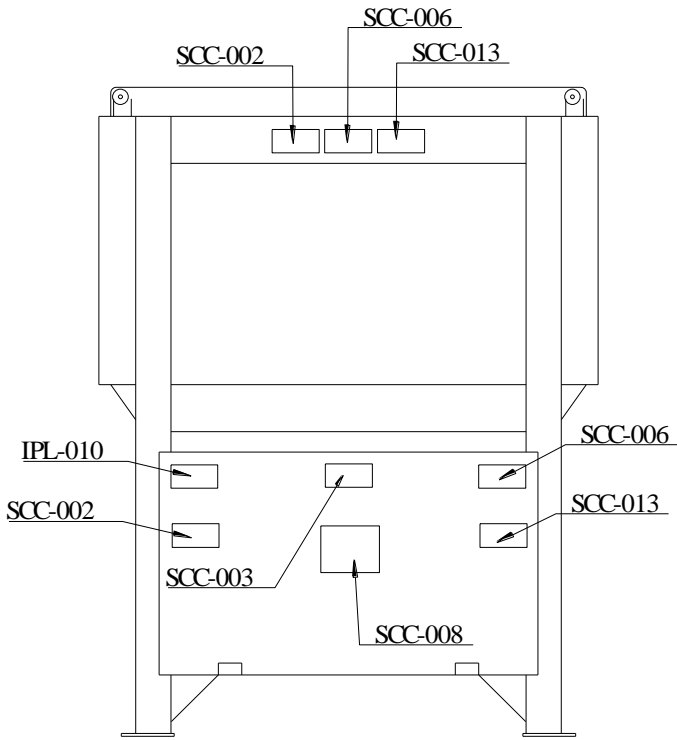
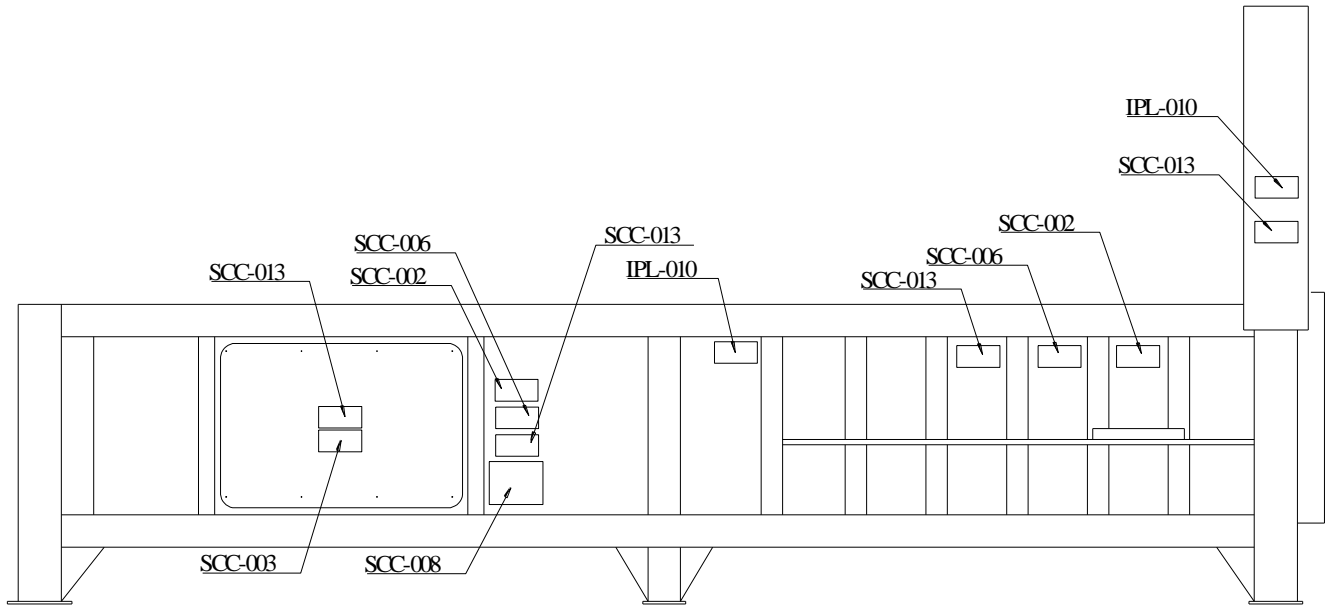

## 7-COMPACTOR OPERATION

### SAFETY ORIENTATION

**INTERNATIONAL CONTAINER** compactors meet or exceed all safety standards set by ANSI. Although we have included many safety features in the design and construction of your compactor, safe operation of your equipment depends on the operator's adherence to certain guidelines. To prevent accidents personnel or damage to the compactor, the operator must **NEVER VIOLATE ANY OF THE FOLLOWING PRECAUTIONS**. It is the owner's/employer's responsibility to ensure these guidelines are known and followed by all operators of the compactor.

**NOTE:** Publication of these safety precautions does not imply or represent an inclusive list.

**NEVER** place hands or arms in the compactor while it is operating.

**NEVER** allow anyone except qualified electrical or hydraulic repair persons to work on the equipment.

**NEVER** disable any safety switch or device.

**NEVER** overload the compactor chamber.

**NEVER** place concrete, heavy steel plate or castings, explosive materials, liquids, or hazardous waste in the compactor.

**NEVER** climb in or on the compactor, nor perform any maintenance/repairs unless the power is disconnected and locked/tagged out.

**NOTE:** Hydraulic oil is the primary power transmission on the compactor. Remember that hydraulic systems can remain pressurized even after the motor has stopped and/or the power has been disconnected. Refer to lock out/tag out procedures in this manual for instructions concerning the neutralization of these energy sources.

#### Z245.2-2013

#### **Stationary compactors-safety requirements for installation, maintenance, and operation.**

Obtain a copy of this standard and become familiar with specific responsibilities and guidelines.

#### **Safety Terminology**

It is important you are familiar with the terminology used on the safety decals and the varying degree of hazards that are associated with this terminology.

**Danger-**Indicates an imminently hazardous situation which, if not avoided, will result in serious injury or death. This signal word is to be limited to the most extreme situations. The signal word DANGER should not be used for property damage hazards unless personnel injury risk appropriate to the level is also involved.

**Warning-** Indicates a potentially hazardous situation which, if not avoided, could result in serious injury or death. This signal word should not be used for property damage hazards unless personnel injury risk appropriate to the level is also involved.

**Caution-** Indicates a potentially hazardous situation, which if not avoided, may result in minor or moderate injury. It may also be used to alert against unsafe practices that may cause property damage.

**Notice-** Indicates a statement of company policy directly or indirectly related to the safety of personnel or protection of property. This signal word should not be associated with directly with a hazard or hazardous situation.

## 8- Compactor operation

### Owner/employer responsibilities for compactors

The employer/owner shall provide properly maintained stationary compactors that meet all applicable regulatory safety requirements and requirements of ANSI Z245.2-2013.

- A)** Ensuring that the installation of the compactor conforms to local, state and federal codes, ordinances, and manufacturer's recommendations. If installing into a system, examine prevailing safety standards of associated equipment.
- B)** Providing to employee's instruction and training in safe work methods before assigning them to operate, clean, service, maintain, modify, or repair the compactor. Such instruction and training shall include procedures provided by the manufacturer. The employer will maintain records as to the names of employees and the dates of training.
- C)** Providing instructions for addressing abnormal situations (e.g., bridging of the loading chamber or feeding chute, jam of materials).
- D)** Assigning only trained employees to work on (which includes operating, loading, cleaning, servicing, maintaining, or repairing) the compactor.
- E)** Monitoring the employee's operation of the compactor and take appropriate action to ensure proper use, including adherence to safe practices and the employee requirements of Z245.2-2013.
- F)** Repairing, prior to placing the compactor into service, any mechanical malfunctions or breakdowns that effect the safe operations of the compactor.
- G)** Establishing and following a program of periodic and regular inspections of all compactors to ensure that all parts, component equipment, and safeguards are in safe operating condition, and adjusted, in accordance with the manufacturer's recommended procedures. This shall include keeping all malfunction reports and records of inspections and maintenance work performed.
- H)** Implementing a program for the maintenance of the compactor which will incorporate the following elements:
  - 1)** Requirements for trained competent maintenance employees or contractors to perform inspection and repair work.
  - 2)** Providing for the cleaning, inspection and repair of the compactor in accordance with the manufacture's recommendations. Including periodic maintenance.
  - 3)** Ensuring that all required safety features are operational and functioning, and repairing, prior to placing into service, any reported malfunction or defect that affects the safe operation of the compactor.
  - 4)** Ensuring that all caution, warning and danger markings required are installed and legible, or are replaced if dam-aged, defaced or missing.
- I)** Utilizing the owner/employers written and manufacturer's recommended procedures for the control of hazardous energy sources (lockout/tag-out) in a program complying with OSHA 29 CFR Subpart S, Electrical; ANSI/NFPA 70E.
- J)** Utilizing the owner/employers written instructions and manufacture's recommended procedures for access control for permit-required confined spaces as part of the employer's program.
- K)** Protecting any person by one of the methods in 5.9.1, AMERICAN NATIONAL STANDARD Revision of ANSI Z245.2-2013, or by other means as effective as those means of protection.
- L)** For compactors fed by means of a loading pit conveyor, reciprocating floor or push pit that is flush with or below the facility floor, provide:
  - 1.** Protection for employees by means of:
    - a)** Limiting access within 6 feet (183) of the edge of the pit to authorized employees.
    - b)** Training authorized employees to recognize and avoid the hazards associated with the pit area.
    - c)** Requiring that others whose employees use the pit area provide assurance of such training.
    - d)** Limiting access by unauthorized persons by installing signs, such as:  
**"RESTRICTED AREA - AUTHORIZED EMPLOYEES ONLY"**
  - 2.** Providing a device to the extent practicable, which prevents trucks or other motor vehicles that unload directly into the loading pit from rolling into the pit.
- M)** When compactor equipped with automatic start/cycling controls are provided, allowing their use only in locations where a startup alarm is utilized, or it is demonstrated that automatic starting does not result in a risk of injury to persons.
- N)** Providing guard railings for dock ramps that meet U.S. Occupational Safety and Health Administration requirements. These shall be located around the loading chamber if walk on ramps are used to deposit refuse into the loading chamber. Guard railings and toe boards shall be provided on the sides of docks and ramps.
- O)** Providing for an adequate work area around the compactor for safe maintenance, servicing, and cleaning procedures.
- P)** Keeping all surrounding walking areas and floor free from obstructions, and from accumulations of waste matter, grease, oil and water.
- Q)** Maintaining records or employees reports of malfunctions.
- R)** Specifically inspecting safety interlocks, switches, and other protective devices to ensure that these devices are not disabled or bypassed, and not to permit the compactor to be operated unless these devices are fully functional. These inspections shall be in accordance with 'G'.
- S)** Ensuring that containers supplied can withstand the maximum forces generated by the compacting system.
- T)** Ensuring that loaders are aware of hazards and safety requirements.
- U)** Ensuring that only authorized employees (18 years or older) operate, inspect, or maintain compactors.
- V)** Incorporating compactors into the employer's safety program.

## 9-Compactor operation (continued)

**Operator and employee responsibilities for compactors** Operators who work on and around the compactor shall be responsible for the items listed below:

- A. Using all applicable safety features provided on the compactor.
- B. Using the compactor only after reading and receiving instruction and training.
- C. Reporting any damage to, or malfunction of the compactor by submitting a report to the employer or responsible authority when the damage or malfunction occurs.
- D. Ensuring that access doors and service openings covers are in place, secure, and/or locked before operation begins.
- E. Ensuring that the area of operation around container/cart lifting systems and the container will be clear of persons during all phases of the lifting operation prior to energizing the dumping system.
- F. Ensuring that all persons are clear of the compactor point of operation before actuating any compaction cycle controls or container/cart lifting system controls and being prepared to stop the compaction cycle or container dumping operation if necessary.
- G. Insuring that all persons are clear of the tailgate (on compactor-container combinations so equipped) before the tailgate is opened or shut. The operator shall warn all persons not to cross behind or under an open tailgate.
- H. Using the compactor in accordance with the manufacturer's instructions, including ensuring the proper position of all locks, doors, guards, etc.
- I. Ensuring that no one disables or bypasses safety interlocks, switches, or other protective devices and that the compactor is not operated unless these devices are fully functional.
- J. Locking out the unit when inspecting malfunctions, jams, or other problems arising from daily operations, servicing, or performing maintenance (except maintenance testing). The affected employee shall identify the type and magnitude of the energy that the compactor uses, shall understand the hazards, and know the methods to control the energy.
- K. Coupling and securing a compatible container to a compactor frame as specified by the compactor and container manufacturers);
- L. Operating, inspecting, and maintaining the compactor only if 18 years old or older and being properly instructed and trained.
- M. Loading, but not operating, the compactor only if 16 years old or older.

## Procedure for the control of hazardous energy sources. (lockout/tag-out)

Before entering any part of the compactor, be sure that all sources of energy have been shut off, all potential hazards have been eliminated, and the compactor is locked-out and tagged-out in accordance with OSHA and ANSI requirements.

The specific Lock-Out and Tag-Out instructions may vary from company to company (i.e. multiple locks may be required, or other machinery may need to be locked-out and tagged-out). The following instructions are provided as minimum guidelines.

1. The owner/employer shall have a hazardous energy control (lockout/tag-out) procedure to follow when performing servicing and maintenance on compactors where the unexpected energization or startup of equipment, or release of stored energy could cause injury to employees.
2. The owner/employer shall utilize the instructions provided by the manufacturer for the control of hazardous energy sources. The lock-out/tag-out procedure shall isolate and render safe all energy sources including electrical, mechanical, hydraulic, pneumatic, chemical, thermal or other potential energy sources (e.g., gravity, etc.). It shall be used to ensure that the compactor is stopped, isolated from all potentially hazardous energy sources and locked out before employees perform any servicing or maintenance where the unexpected energization or startup of the compactor or release of stored energy could cause injury.
3. The lockout/tag-out procedure shall include but is not limited to the following:
  - a) Performing a hazard assessment.
  - b) Wearing the proper personal protective equipment.
  - c) Shutting down all power sources.
  - d) Removing keys or other devices that enable the compactor.
  - e) Using a lock to secure the power supply or, if that is not feasible, installing a tag on an appropriate location, using a non-reusable fastener, or installing a similar warning device.
  - f) Placing operating components in such a position so as not to be subject to possible free fall and/or installation of additional blocking devices to prevent such free fall of any raised or elevated component.
  - g) Relieving stored hydraulic or pneumatic pressure, after blocking devices are installed, if maintenance is to be done to the hydraulic or pneumatic system.

**Note:** Removing key switch by itself is not sufficient for lockout/tagout

4. The procedure shall address the following:

- a) Sequence of lockout for the compactor.
  1. Notify all affected employees that servicing or maintenance is required on a compactor and that the compactor must be shut down and locked out to perform the servicing or maintenance.
  2. The authorized employee shall refer to the company procedure to identify the type and magnitude of the energy that the compactor utilizes, shall understand the hazards of the energy, and shall know the methods to control them.
  3. If the compactor is operating, it must be shut down by the normal stopping procedure (depress stop button, open switch, close valve, etc.).
  4. De-activate the energy isolating device(s) so that the compactor is isolated from the energy source(s).
  5. Lock out the energy isolating device(s) with assigned individual lock(s).
  6. Stored or residual energy must be dissipated or restrained by methods such as grounding, repositioning, blocking, bleeding down, etc.
  7. Ensure that the compactor is disconnected from the energy source(s) by first checking that no personnel are exposed, then verify the isolation of the equipment by operating the push button or other normal operating control(s) or by testing to make certain the equipment will not operate. **Caution:** Return operating control(s) to neutral or "off" position only after verifying the isolation of the equipment.

## 10-Compactor operation (continued)

8. Before entering stationary compactor perform hazard assessment for confined space requirements (i.e., hazardous fumes, dust or other toxic material).

**NOTE:** The machine or equipment is now locked out

b) Restoring the compactor to service. When the servicing or maintenance is completed and the compactor is ready to return to normal operating condition, the following steps shall be taken:

1. Check the machine or equipment and the immediate area around the machine or equipment to ensure that all nonessential items have been removed and the machine or equipment components are operationally intact.
2. Check the work area to ensure that all employees have been safely positioned or removed from the area.
3. Verify that the controls are in neutral.
4. Remove the lockout devices and re-energize the machine of equipment. **NOTE:** The removal of some forms of blocking may require re-energizing of the machine before safe removal.
5. Notify affected employees that the servicing or maintenance is completed, and the machine or equipment is ready for use.
6. Reassess area to determine that the equipment is safe for operation.

5. Procedures for work in confined spaces:

a) The owner/employer shall have a written procedure for work in confined spaces meeting the criteria of "permit required confined spaces," such as integrated power units. The procedure shall utilize the manufacturer's instructions for the hazardous energy control (lockout/tag-out) procedure which shall isolate and render safe energy sources, including electrical, mechanical, hydraulic, pneumatic, chemical, thermal or other potential sources of energy (e.g., gravity, kinetic, etc.), which may create a hazard during entry into each of those confined spaces

b) These instructions shall include the requirement to affix a sign to the compactor, at or near the entrances to those confined spaces for which hazardous energy control procedures are provided, such as, "DANGER — Confined Space. Follow lockout/tag-out procedures."

## Procedure for electrical arc flash and shock safety

1. Prior to intentionally coming into contact with energized electrical conductors or circuit parts of 50 volts or greater with the hands, feet, or other body parts, with tools, probes (energized electrical work), a shock and hazard analysis shall be performed to determine the safe work practices that are required to perform that work (per the requirements of ANSI/NFPA 70, *National Electrical Code*).
2. Those safe work practices shall include the identification of the following, at a minimum:
  1. Energized electrical work shall only be performed by or under the direct supervision of a trained Qualified Person.
  2. All other workers performing energized electrical work shall be trained in the following, at a minimum:
    - a) Understanding the specific hazards associated with electrical energy.
    - b) Understanding the safety-related work practices and procedural requirements necessary to provide protection from the electrical hazards associated with their respective job or task assignments; and
    - c) Identifying and understanding the relationship between electrical hazards and possible injury.

## Safety and training program

**General:** Employers shall evaluate and manage safety issues related the operation of compaction equipment as part of their safety program.

### Safety Program

The employer's program shall include at a minimum the following elements:

- a) A hazard assessment in which the employer conducts a review of the various types of compaction equipment that the employer utilizes, and the hazards associated with them and, review and assess the capabilities, qualifications and training of any person who may potentially encounter these hazards.
- b) An evaluation of the means and methods of controlling the hazards identified in the hazard assessment, including information such as industry and regulatory requirements, instructions for the operation, inspection, and maintenance of compactors, and other information appropriate to the hazards that are identified.
- c) A written program, based upon the hazard assessment and evaluation, to include procedure for the operation, inspection, and maintenance of compactors, prohibited practices, record keeping, training requirements, and normative references to documents, such as operating manuals, that are relied upon and may be required as part of that program.
- d) Periodic review and program revisions as necessary to ensure the effectiveness of the safety program.

## 11-Compactor Operation

### General training

Employers shall ensure all employees, including supervisors, contract laborers, and all other persons engaged in the operation, cleaning, maintenance, service or repair of compacting equipment are properly trained appropriate for their assigned jobs and tasks. Contractors who may be engaged to operate or maintain the employer's compactor shall be advised of the unique hazards related to the equipment that may affect the activities in which the contractor's employees will engage.



## CAUTION

It is unlawful to operate this machine if you are under 18 years of age!

### Emergency Procedures

Should an emergency occur while operating the Pre-Crusher, press the RED EMERGENCY STOP BUTTON and the Pre-Crusher will terminate all functions and shut down. **EVERYONE AUTHORIZED TO OPERATE THE PRE-CRUSHER SHOULD KNOW THIS EMERGENCY PROCEDURE.**

## Pre-Crusher Operation

1. If the wall is not down the next time the Start button is pushed the main ram will fully retract and the wall will lower. Once the wall is down normal operation can continue.
2. Once you press the green start button the PLC will look for the ram limit switch to be made as well as the start button to be made. Once the ram moves forward you can let go of the green start button.
3. The ram will run forward and crush against the gate. Once the Ram pressure switch is activated the Ram will retract for fixed seconds and the wall will begin to go UP.
4. Once the wall is all the way up and closes the Gate limit switch, the ram will push the rest of the way into the container until the Forward limit switch is activated.
5. Once the Forward limit switch is activated the ram will fully retract until the ram closes the retract limit switch. Once the ram is fully retracted the wall will lower and once the Gate pressure switch is activated the motor will shut off.
6. Container full will activate only when the Gate is all the way up and the ram moves forward past the Gate. When the container is full it will shut the unit down and turn on a light.

## 12- Maintenance

# Authorized Technician Maintenance

## Lock-out & Tag-out Instructions



**FORWARD:** Before entering any part of the Pre-Crusher, be sure that all sources of energy have been shut off, all potential hazards have been eliminated, and the Pre-Crusher is locked-out and tagged-out in accordance with OSHA and ANSI requirements. If the ram is pressing against a load, move the ram rearward before shutting the Pre-Crusher down. The specific lock-out and tag-out instructions may vary from company to company (i.e. multiple locks may be required, or other machinery may need to be locked-out and tagged-out). The following instructions are provided as minimum guidelines.

### INSTRUCTIONS

1. Move the main disconnect lever to the OFF position.
2. Padlock the disconnect lever with a keyed padlock and take the key with you.
3. Along with the padlock, place an appropriate, highly visible, warning tag on the disconnect lever. The tag should provide a warning such as "Danger: Do not operate equipment. Person working on equipment" or "Warning: Do not energize without permission of \_\_\_\_\_".
4. After locking and tagging the Pre-Crusher, try to start and operate the Pre-Crusher (as outlined in the Operating Instructions) to make sure the lock-out and tag-out is effective. If the lock-out and tag-out is effective, remove the key from the key-switch and take it with you.

**ELECTRICAL:** The motor control panel contains high voltage components. Only authorized service personnel should be allowed inside the panel. Authorized service personnel should be allowed inside the panel only after the Pre-Crusher has been locked-out and tagged-out.

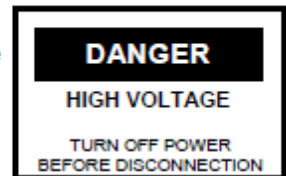

**HYDRAULIC:** Stored hydraulic energy must be removed from the Pre-Crusher hydraulic circuit for complete lock-out and tag-out. Make sure that this energy has been relieved by manually depressing the solenoid valve pin located in the center of each coil end of the directional valve.

Manual Operating Pin (both ends).

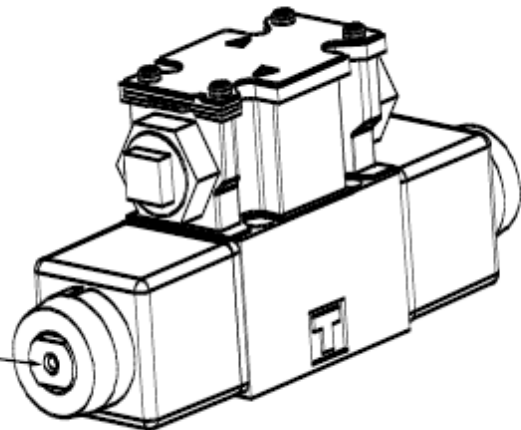

## 13-Maintenance

# Authorized Technician Maintenance, cont.

HYDRAULIC SAFETY: PLEASE READ CAREFULLY!



**Warning:** Escaping fluid under pressure can penetrate the skin causing serious injury. Avoid the hazard by relieving pressure before disconnecting hydraulic lines. Tighten all connections before applying pressure. Search for leaks with a piece of cardboard. Protect hands and body from high pressure fluids.

If an accident occurs, see a doctor immediately. Any fluid injected into the skin must be surgically removed within a few hours or gangrene may result.

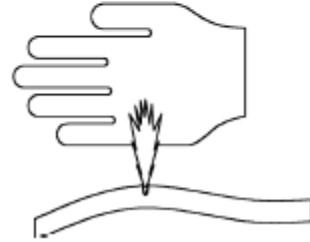

### AVOID HEATING NEAR PRESSURIZED HYDRAULIC HOSES

Flammable spray can be generated by heating near pressurized hydraulic hoses, resulting in severe burns to yourself and bystanders. Do not heat by welding or using a torch near hoses. Hose can be accidentally cut when heat goes beyond the immediate flame area.

### THE FOLLOWING WARNINGS PERTAIN TO THE MORE COMMON ABUSES OF HYDRAULIC HOSE:

1. INSPECT the hose assembly before each use.
2. Contact ICC Service Department or your hydraulics specialist if:
  - a. The jacket of the hose appears abnormal.
  - b. You have reason to believe it may be abnormal.
  - c. There is any fluid leakage.
  - d. The couplings are damaged.
  - e. The hose is damaged or kinked.
  - f. The reinforcement is visible through the jacket.
3. DO NOT **EXCEED** the maximum recommended working pressure of the hose.
4. DO NOT **KINK** the hose assembly.
5. DO NOT **BEND** the hose assembly beyond its minimum recommended bend radius.
6. DO NOT **EXPOSE** to temperatures in excess of 225 degrees Fahrenheit.
7. DO NOT USE AS A **STRENGTH MEMBER** for pulling or lifting equipment.

### Caution:

If replacing hydraulic hose, use only hose that meets or exceeds 3,000 PSI working pressure.

**IMPORTANT: ANY REPAIR TO THE MACHINE SHOULD BE DONE BY AN AUTHORIZED TECHNICIAN, THERE ARE NO USER SERVICABLE PARTS ON ANY OF OUR MACHINES!**



## 14-Maintenance

### PREVENTIVE MAINTENANCE

We recommend the user of International Container Pre-Crushers adopt a program of regularly scheduled maintenance procedures. This schedule should be followed to insure against premature failure of mechanical or hydraulic components.

#### 1. INITIAL CHECK:

- a. All nuts and bolts during the first week of use, and then monthly thereafter.
- b. Hydraulic reservoir should be at the mid to upper range of the sight glass with ram retracted. Use a good quality hydraulic fluid.
- c. Hydraulic lines for leaks.
- d. Hydraulic hose condition. (Check for damage, kinks, etc.).
- e. Access covers to be sure fasteners are in place.
- f. Power unit. Remove dust and dirt from outside of control box. Wipe off any dirt or grease, oil or moisture.

#### 2. MONTHLY CHECK

- a. Check external hoses for chafing, rubbing, or other deterioration and damage.
- b. Check for any obvious unsafe conditions, such as electrical lines or operator obstructions, in Pre-Crusher area.
- c. Check oil level in hydraulic reservoir.

#### 3. 3 MONTH CHECK:

- a. Check functional operation of standard controls and options (stop button, timers, lights, etc.).
- b. Open door and clean out above and around ram. Clean out any accumulation of waste material.
- c. Check hydraulic cylinder and hoses for leakage, hoses for chafing and wear.

#### 4. YEARLY CHECK:

- a. Electrician to check all electrical connections, check motor resistance (recording successive readings helps prevent future failure), Under heavy use, grease the motor. (DO NOT OVER-GREASE).
- b. Hydraulic system—drain, replace filter, and clean inside of reservoir by removing drain plug. Replace plug and refill. Check for tightness. Refill reservoir with high quality hydraulic fluid.
- c. Check structure for potential trouble areas and repair as needed.
- d. Check hoses to ensure that they do not become severely worn before being replaced. A broken hose will allow the reservoir to be pumped dry and ruin the pump.
- e. Check condition of ram guide shoes. Replace if necessary. Keeping the slide material replaced, when necessary, will greatly extend the life of the Pre-Crusher sides.

### LUBRICATION:

**NOTE:** Clean-out or maintenance requires the gate to be open but be sure the Pre-Crusher ram is extended first. To EXTEND the ram - - first turn the “start” switch and fully extend the ram. When ram is fully extended, press the “STOP” button, and remove the key, lockout/tag-out the power, then the door can be opened.

### Warning

Before opening door or entering bale chamber, make absolutely sure main disconnect power box is shut off and locked, with key to said lock in possession of person entering bale chamber or area behind bolted access covers. A tag should also be attached to the disconnect stating “UNDER REPAIR, DO NOT USE”, with person’s name on the tag who is entering above the ram.

### Warning

This procedure is for maintenance only. All access covers or doors shall be replaced and bolted into position after lubrication or clean-out.

# 15-Maintenance

## TROUBLE-SHOOTING CHART

Note: Before performing any maintenance, always LOCK AND TAG-OUT THE DISCONNECT.

<u>Problem</u>	<u>Solution</u>
Motor will not operate.	<ol style="list-style-type: none"><li>1. Check main breaker.</li><li>2. Check hopper door and safety switch.</li><li>3. Check fused disconnect.</li><li>4. Check motor starter thermal overloads. Reset if necessary.</li><li>5. Check motor starter coil.</li><li>6. Check magnetic door switch (if applicable)</li><li>7. Check that the power on indicator is on.</li></ol>
Motor runs but ram does not move.	<ol style="list-style-type: none"><li>1. Check for proper motor rotation. (clockwise from the fan end).</li><li>2. Check hydraulic fluid level.</li><li>3. Check the directional valve for proper operation.</li><li>4. Check relief valve for proper adjustment.</li><li>5. Check the limit switch.</li><li>6. Check the motor to pump coupler.</li><li>7. Check the extend solenoid on the ram directional valve is energized.</li><li>8. Check that the directional valve is not stuck.</li><li>9. Check that the proper outputs of the PLC are energized.</li></ol>
Pre-Crusher shifts erratically.	<ol style="list-style-type: none"><li>1. Check for proper system pressure.</li><li>2. Check for proper pressure switch adjustment.</li><li>3. Check directional valve.</li><li>4. Check limit switch.</li></ol>
Pre-Crusher makes excessive noise.	<ol style="list-style-type: none"><li>1. Check hydraulic fluid level.</li><li>2. Check ram guide for lubrication.</li><li>3. Check for water or air in hydraulic fluid.</li><li>4. Check oil filter and suction line components for tightness.</li><li>5. Check that the cylinder is not leaking from the rod seal, indicating seal failure.</li><li>6. Check that the ram guides are properly adjusted.</li></ol>
Motor starts but does not stay running.	<ol style="list-style-type: none"><li>1. Check that the motor overloads are operating properly.</li><li>2. Check that the power outputs of the PLC are energized.</li><li>3. Check that the stop button is not stuck.</li></ol>
The 75% light never illuminates.	<ol style="list-style-type: none"><li>1. Check for pressure switch failure or adjustment.</li></ol>
The 100% light never illuminates.	<ol style="list-style-type: none"><li>1. Check for pressure switch failure or adjustment.</li></ol>

# 16-Installation

## CONCRETE PAD REQUIREMENTS

**Caution:** Review this manual before making the installation. Study the jobsite and installation requirements carefully to be certain all necessary safeguards and or safety devices are provided to protect all personnel and equipment during installation and as a completed system. Special attention is directed to the extract from American National Institute Z245.2.

**INTERNATIONAL Container Company does not assume responsibility for the installation procedures of this equipment. Conformance to applicable local, state, and federal laws concerning installation rest with the customer.**

### CONCRETE PAD

1. Preferred dimensions of the concrete pad are 10 ft. wide and a length of 45 ft. It should be level and of minimum 3000 PSI concrete reinforced, 6 in. thick.
2. To provide accessibility, concrete pad should be positioned to allow 2 ft 4 in between machine and building wall if in-stalled parallel with building. Allow a minimum of 45 ft of clear space from end of pad for container handling vehicle.

Note: The clearances given are minimums. Your installation may require greater clearances depending on the site and the hauling equipment that will be used.

### POSITIONING

Position the Pre-Crusher so that sufficient room is available for proper and safe operation.

### ANCHORING

Position the Pre-Crusher so that sufficient room is available for proper and safe operation.

The Pre-Crusher should be anchored to the pad with anchor bolts (minimum 3/4" x 5"). To allow for construction variances, the holes should be drilled after locating the Pre-Crusher in the desired position.

## 17-Installation, cont

### ELECTRICAL AND HYDRAULIC INSTALLATION



The motor control panel contains high voltage components. Only authorized service personnel should be allowed inside. See Lock-Out and Tag-Out instructions in the maintenance section.



A lockable fused disconnect switch (customer furnished) must be installed and be within sight of the Pre-Crusher motor control panel location, not to exceed 50' 0" from the Pre-Crusher. This fused disconnect switch should be sized in accordance with the Pre-Crusher.

### GROUNDING INSTRUCTIONS

This appliance must be connected to a grounded, metal, permanent wiring system; or an equipment-grounding conductor must be run with the circuit conductors and connected to the equipment-grounded terminal or lead on the appliance.

### PUSH BUTTON OPERATOR STATION

If a remote operator station is furnished, it will be factory wired using Sealtite. If it is necessary to disconnect it from the wires (to install the operator station inside a building), exercise care that these wires are reconnected as originally furnished. (Check local codes to be certain that Sealtite is acceptable).

**CAUTION:** Operator Station should be located so that the Mushroom (Emergency) Stop Button is readily accessible to the operator and within three (3) feet of the charging chamber access door. If installation requires the operator station to be located in a more remote area, a second Emergency Stop Button should be added and installed in the manner described above.

REF. ANSI Z245.2-2004 5.7.2 Emergency stop controls shall be readily accessible to the operator or shall be located within 3 ft (91.4 cm) of the point of operation, the material feed area, or if chute fed, within 3 ft (91.4 cm) of the access door.

### ELECTRICAL CONNECTIONS

1. Run power lines, between fused disconnect switch (customer furnished) and Pre-Crusher's motor control panel, in accordance with local electrical codes, using knock-outs in bottom of motor control panel.
2. Check voltage at fused disconnect to be certain it is the same as is shown on Pre-Crusher or remote power pack. If voltage is correct, put fused disconnect switch in "ON" position.
3. Check motor wiring, voltage, motor rotation.
4. Check motor starter, thermal overload selector and voltage.

### START-UP INSTRUCTIONS

1. With the ram fully retracted, check to be sure the oil reservoir is full to the 3/4 level on the sight gauge. The hydraulic system pressure has been factory set, and the entire unit has been operated prior to shipment.
2. **CAUTION: MAKE SURE PERSONS AND MATERIAL ARE CLEAR OF CHARGE BOX AREA.**
3. Depress the start button and check the pump for proper rotation. **CAUTION: If pump rotates backward, stop immediately.** The pump will be damaged if it is operated in reverse even for short periods. Reversing any two incoming power lines will change the motor/pump rotation.
4. Make sure that the operators are trained in the proper use of this equipment.

## LEGAL PROVISIONS

### Limitation on Liability

1. TO THE MAXIMUM EXTENT PERMITTED BY APPLICABLE LAW, THE RIGHTS AND REMEDIES SET FORTH HEREIN (WHETHER BY WAY OF DAMAGES, PAYMENT OR REIMBURSEMENT OF COSTS, PRICE REDUCTION, MAKE GOOD OR REMEDIATION, TERMINATION OR OTHERWISE) SHALL BE ITS SOLE AND EXCLUSIVE RIGHTS AND REMEDIES REGARDLESS OF THE EVENTS, CIRCUMSTANCES OR THEORY ON WHICH A CLAIM MAY BE BASED (INCLUDING TERMINATION, BREACH OF CONTRACT OR STATUTORY DUTY, NEGLIGENCE OR OTHER TORT, STRICT LIABILITY, INDEMNITY, RESCISSION / WITHDRAWAL OR OTHERWISE).

2. Notwithstanding any other provision to the contrary or the failure of the essential purpose of any exclusive or limited remedy, except only to the extent the exclusion of International Container Company's liability is limited by applicable law (in which circumstances International Container Company's liability shall be limited to the greatest extent permitted by applicable law):

**INTERNATIONAL CONTAINER COMPANY SHALL IN NO CASE WHATSOEVER BE LIABLE FOR ANY (A) LOSS OF REVENUES OR PROFITS; LOSS OF OPPORTUNITY, PRODUCTION OR CONTRACTS; LOSS OF USE; STANDBY COSTS; LOSS OF OR DAMAGE TO UTILITIES OR PRODUCT; PLANT DOWNTIME OR DELAYS; LOSS OF GOODWILL; LIQUIDATED DAMAGES OR PENALTIES; CONTRACTUAL LIABILITY TOWARDS ANY THIRD PARTY; COSTS TO RECALL THE PRODUCT; ANY DAMAGES FINES OR PENALTIES; OR OTHERWISE FOR ANY FINANCIAL OR ECONOMIC LOSSES OR DAMAGES, AND IN EACH CASE IRRESPECTIVE WHETHER THE LOSSES OR DAMAGES IN QUESTION ARE DEEMED OR CLAIMED TO BE DIRECT, CONSEQUENTIAL, INDIRECT OR OTHERWISE, OR (B) FOR ANY CONSEQUENTIAL, INDIRECT, SPECIAL, INCIDENTAL, PUNITIVE OR EXEMPLARY, LOSSES OR DAMAGES HOWSOEVER CAUSED OR ARISING; OR (C) FOR ANY LOSS OR DAMAGE TO THE EXTENT ARISING OUT OF THE SOLE OR CONTRIBUTORY NEGLIGENCE OF YOU, YOUR EMPLOYEES OR AGENTS OR ANY THIRD PARTY.**

3. Notwithstanding any other provision to the contrary or the failure of the essential purpose of any exclusive or limited remedy, except only to the extent the exclusion or limitation of International Container Company's liability is prohibited by applicable law (in which circumstances International Container Company's liability shall be limited to the greatest extent permitted by applicable law):

**INTERNATIONAL CONTAINER COMPANY'S MAXIMUM AGGREGATE LIABILITY TO YOU OR ANYONE OPERATING THE [PC-400/PC-500/PC-600 PRECRUSHER COMPACTOR] SHALL IN NO CASE EXCEED THE GREATER OF THE PRICE PAID FOR OR REMAINING FAIR MARKET VALUE OF THE [PC-400/PC-500/PC-600 PRECRUSHER COMPACTOR], IRRESPECTIVE WHETHER SUCH LIABILITY ARISES BY WAY OF BREACH OF CONTRACT OR OF STATUTORY DUTY, NEGLIGENCE OR OTHER TORT, STRICT LIABILITY, INDEMNITY, CONTRACT PRICE REDUCTION OR REPAYMENT, TERMINATION, RESCISSION/WITHDRAWAL, MAKE GOOD OR REMEDIATION OR OTHERWISE.**

4. No provision herein shall be deemed to expand or extend any provision of any other written document provided by International Container Company. Use of the [**PC-400/PC-500/PC-600 STATIONARY COMPACTOR**] is done at your sole risk and all procedures and policies shall be strictly followed. To the extent any waiver or disclaimer contained herein is deemed unlawful or unenforceable under applicable law, such waiver or disclaimer shall be deemed to be removed herefrom but only to such extent necessary to make such waiver or disclaimer compliant with applicable law.

### Warranties; Disclaimers

1. International Container Company only provides the warranty set forth in its separate warranty policy and no other warranty. TO THE FULLEST EXTENT PERMITTED BY LAW, INTERNATIONAL CONTAINER COMPANY DISCLAIMS ALL REPRESENTATIONS AND WARRANTIES OF ANY KIND, WHETHER EXPRESS, IMPLIED OR STATUTORY, INCLUDING, BUT NOT LIMITED TO, THE IMPLIED WARRANTIES OF TITLE, QUALITY, PERFORMANCE, MERCHANTABILITY, SUITABILITY, FITNESS FOR A PARTICULAR PURPOSE, ACCURACY AND NON-INFRINGEMENT RELATED TO OR ARISING FROM THE [**PC-400/PC-500/PC-600 PRECRUSHER COMPACTOR**] AS WELL AS WARRANTIES IMPLIED FROM ANY ALLEGED COURSE OF DEALING OR COURSE OF PERFORMANCE. INTERNATIONAL CONTAINER COMPANY DOES NOT WARRANT THAT THE **PC-400/PC-500/PC-600 STATIONARY COMPACTOR** WILL

PROVIDE CONTINUOUS, PROMPT, SECURE, OR ERROR-FREE SERVICE. INTERNATIONAL CONTAINER COMPANY ASSUMES NO LIABILITY FOR ANY ERRORS OR OMISSIONS, INCLUDING THE INACCURACY OF CONTENT, OR FOR ANY DAMAGES OR LOSSES THAT YOU OR ANY THIRD-PARTY MAY INCUR AS A RESULT OF THE UNAVAILABILITY OR FAILURE OF **[PC-400/PC-500/PC-600 STATIONARY COMPACTOR]**.

2. International Container Company's responsibility under any warranty is subject to the condition that the underlying defect is not caused by one or more of the following: (i) use of non-original spare parts; (ii) use not in strict conformity with the specifications stated in International Container Company's written manuals and materials; (iii) any failure of upstream and/or downstream equipment necessary for the product to function properly; (iv) modifications without International Container Company's express prior written consent; (v) use of corrosive or abrasive substances; or (vi) the storage, handling, use, operation or maintenance of the product which is not in strict conformity with good engineering practice and any written requirements of International Container Company's written manuals and materials.

3. Any remedies set forth in the warranty policy shall be the sole and exclusive remedies in respect of any warranty obligation and International Container Company shall not be liable for any loss or damage caused by or resulting from any breach of warranty. If it is ultimately determined that this remedy fails of its essential purpose, then International Container Company's maximum liability is limited to the **[PC-400/PC-500/PC-600 STATIONARY COMPACTOR]**.

4. The expiration of any applicable warranty period shall, to the maximum extent permitted by applicable law, constitute conclusive evidence for all purposes and in all proceedings whatsoever between the parties that International Container Company has completed its obligations under or arising out of the warranty offered by International Container Company. After the expiration of any applicable warranty period, all claims of any nature whatsoever that may exist against International Container Company, whether known or not, under or arising out of the applicable warranty, and any right, cause of action and or remedy shall be deemed to be barred and extinguished.

#### Forum Selection Clause

1. The exclusive jurisdiction and the exclusive venue of the resolution of any dispute arising from the provisions of this Manual or use of the **[PC-400/PC-500/PC-600 STATIONARY COMPACTOR]** shall lie with the Superior Court of Massachusetts, Hampden County.