

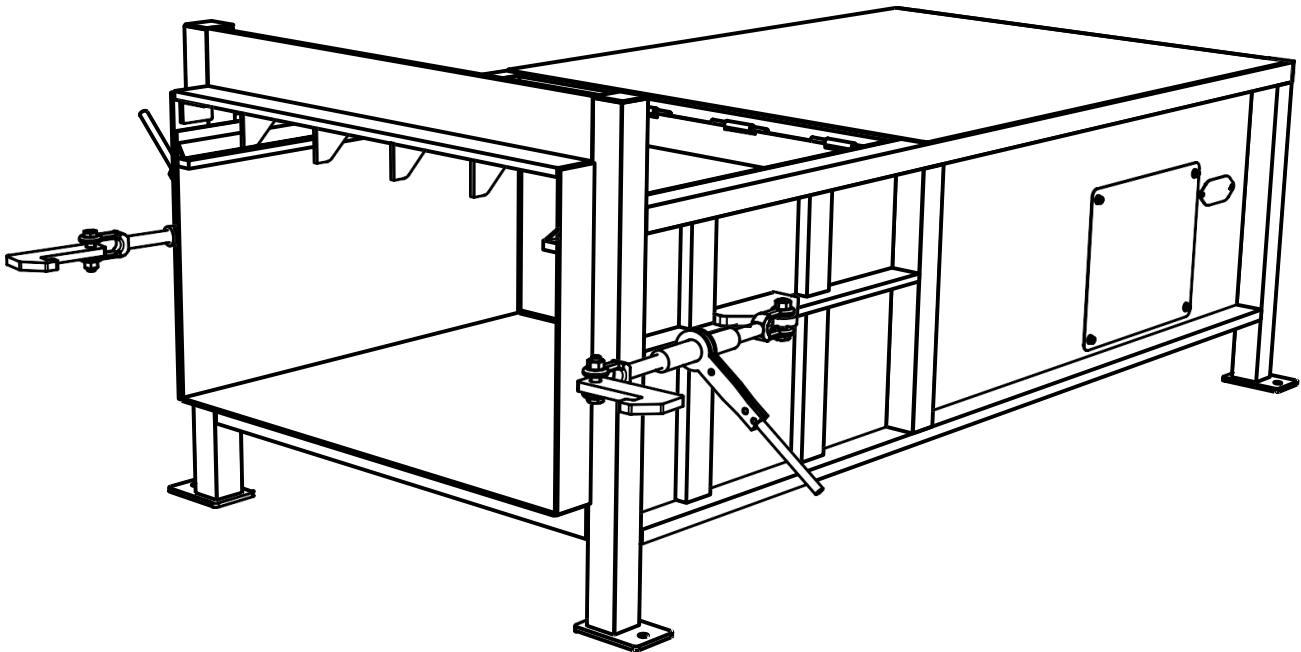

OPERATION, MAINTENANCE AND INSTALLATION MANUAL

FOR
SC-200/SC-250/SC-300
STATIONARY COMPACTOR



INTER  PAK
COMPACTION UNITS

MANUFACTURED BY: INTERNATIONAL CONTAINER CO., LLC
110 NORTH BRIDGE ST., HOLYOKE, MA 01040

TABLE OF CONTENTS

- 1- INTRODUCTION
- 2- GENERAL SPECIFICATIONS
- 3- CHARGE BOX SPECIFICATIONS
- 4/5-LOCK OUT/TAG OUT PROCEDURES
- 6- PREOPERATION INSTRUCTIONS
- 7- OPERATIONAL SAFETY INSTRUCTIONS
- 8- OPERATIONAL CONTROL PENDANT DISCRPTION
- 9- OPTIONAL CONTROLS
- 10-OPERATING INSTRUCTIONS
- 11-DECAL IMAGES
- 12-DECAL PART NUMBERS
- 13-DECAL PLACEMENT
- 14-DECAL PLACEMENT LOADING OPTIONS
- 15-PERIODIC MAINTENANCE
- 16-TROUBLESHOOTING
- 17-INSTALLATION
- 18-DOCK INSTALLATION
- 19-THRU WALL INSTALLATION
- 20-ELECTRICAL/HYDRAULIC INSTALLATION
- 21-ELECTRICAL/HYDRAULIC INSTALLATION
- 22-INSTALLATION STARTUP
- 23- LEGAL PROVISIONS

CAUTION: Review this manual before making the installation. Study the jobsite and the installation requirements carefully to be certain all necessary safeguards and/or safety devices are provided to protect all personnel and equipment during installation and as a complete system. Special attention is directed to the most current extract from American National Standards Institute Z245.2. These instructions are not intended as a substitute for proper training and experience in proper use and safety procedures in operating this equipment. International Container Co. does not assume responsibility for the installation procedures of this equipment. Conformance to local, state, and federal laws concerning installation rests with the customer.

INTRODUCTION

THANK YOU FOR PURCHASING AN INTERNATIONAL CONTAINER STATIONARY COMPACTOR

This compactor is designed to give you reliable and superior performance for many years to come. The purpose of this manual is to provide the owner(s) and/or operator(s) with the necessary information to properly install, operate, and maintain your stationary compactor. This manual **IS NOT** intended as a primary training source, but as a reference guide for authorized, trained personnel. Each person involved in the operation, maintenance, and installation of the machine should read and thoroughly understand the instructions in this manual and follow **ALL** warnings prior to operation.

The owner(s) and/or employer(s) involved in the operation, maintenance, and installation of this compactor should always read and understand the most current version of the following applicable standards:

ANSI-Z245.2

“STATIONARY COMPACTOR REQUIREMENTS”

A copy of this standard may be

obtained from: ANSI

25 West 43rd Street

New York, New York 10036

OSHA 29 CFR, Part 1910.147

“The control of hazardous energy (lock-out/tag-out)”

Employer(s)/Equipment owners are responsible for the safe installation, training, and operation of this equipment. Final installation requirements must be met by the installer. Employer(s)/Equipment owners are responsible for establishing and implementing a lock-out/tag-out procedure. This manual serves only a guideline for these procedures.

Any service or repairs recommended by this manual should be performed by factory authorized personnel only.

If you need assistance with your compactor, please contact International Container Co., LLC. When contacting, you will need to provide the compactor serial number, installation date, and power unit serial number.

If you have any safety concerns with the equipment, or need further information, please contact us at:

INTERNATIONAL CONTAINER CO., LLC
110 N. Bridge St., Holyoke, MA 01040
413-538-9200
office@internationalcontainerco.com

In addition to this operation, maintenance, installation manual, an additional instructional manual is provided with each power unit. Please read all comprehensive instructions and information in both manuals prior to operation, maintenance, or installation. THIS MACHINE IS INHERENTLY DANGEROUS AND FAILURE TO FOLLOW THE INSTRUCTIONS CONTAINED IN THESE MANUALS MAY RESULT IN SERIOUS INJURY OR DEATH!



WARNING

IF INCORRECTLY USED, THIS EQUIPMENT CAN CAUSE SEVERE INJURY. THOSE WHO USE AND MAINTAIN THE EQUIPMENT SHOULD BE TRAINED IN ITS PROPER USE, WARNED OF ITS DANGERS, AND SHOULD READ AND FULLY UNDERSTAND THIS ENTIRE MANUAL BEFORE ATTEMPTING TO SET UP, OPERATE, ADJUST OR SERVICE THE EQUIPMENT. KEEP THIS MANUAL FOR FUTURE REFERENCE

2

GENERAL SPECIFICATIONS

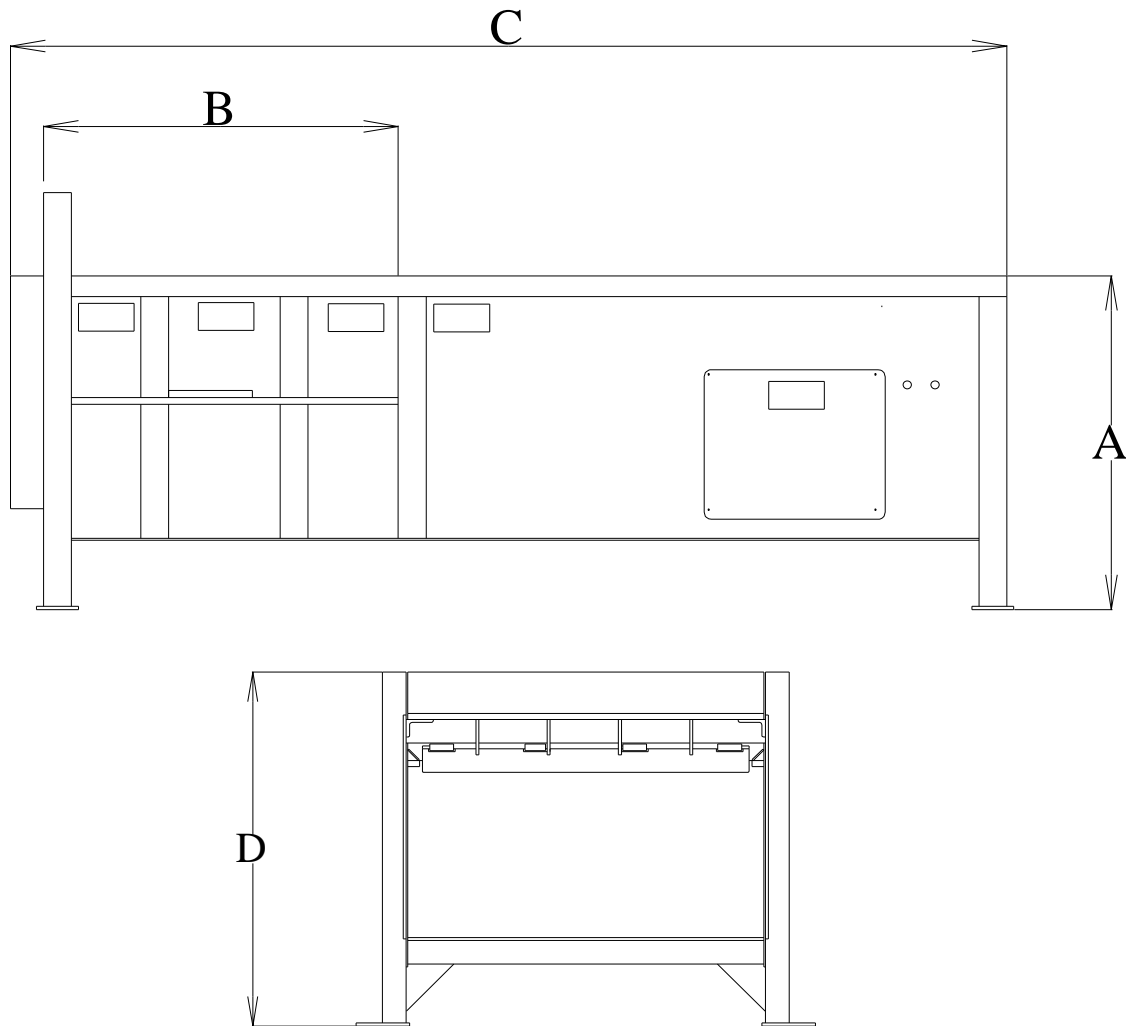

	SC-200	SC-250	SC-300
A-LOAD HEIGHT:	48"	48"	48"
B-CLEAR TOP OPENING:	41"X 60"	50"X 60"	66"X 60"
C-MAX LENGTH:	124"	143.5"	176"
D-MAX HEIGHT:	60"	60"	60"
MAX WIDTH:	77.5"	77.5"	77.5"
CHARGE BOX MAX CAPACITY(MFR):	2	2.5	3

3

CHARGE BOX SPECIFICATIONS

	SC-200	SC-300	SC-400
-CLEAR TOP OPENING-	41" X 60"	50" X 60"	66" X 60"
-LOAD HEIGHT-	48"	48"	48"
-*CYCLE TIME(SEC)-	73	80	58
-*RELIEF PRESSURE:	2000 PSI	2000 PSI	2000 PSI
- MOTOR HP:	10	10	15
-*PUMP CAPACITY(GPM):	10.5	10.5	18
-*RESERVOIR CAPACITY(GAL):	25	25	40
- HYDRAULIC CYLINDER:			
BORE:	6"	6"	6"
ROD:	2.5"	3"	3"
STROKE:	56"	65"	82"
-RAM PENETRATION:	15"	15"	15"
GUIDES: NYLATRON 3-POINT SYSTEM			

*- Varies depending on power unit manufacturer, and model of power unit.
Please consult the manual provided in power unit of this compactor.

NOTE: Cycle times may vary due to power unit size, manufacturer, voltage, etc.
Actual cycle time settings must be adjusted at the time of installation.

LOCK-OUT/TAG-OUT INSTRUCTIONS

Before entering any part of the compactor, be sure that all sources of energy have been shut off, all potential hazards have been eliminated, and the compactor is locked-out and tagged-out in accordance with OSHA and ANSI requirements.

The specific Lock-Out and Tag-Out instructions may vary from company to company (i.e. multiple locks may be required, or other machinery may need to be locked-out and tagged-out). The following instructions are provided as minimum guidelines.

INSTRUCTIONS

1. Notify all affected employees that servicing, or maintenance is required on the compactor and that the compactor must be shut down and locked-out to perform the servicing or maintenance.
2. Perform a hazard assessment.
 - a. The authorized employee shall refer to the company procedure to identify the type and magnitude of the energy that the compactor utilizes, shall understand the hazards of the energy, and shall know the methods to control the energy.
3. Wear proper personal protective equipment.
4. If compactor is operating, it must be shut down by the normal stopping procedure. If the ram is pressing against a load, move the ram rearward before shutting the compactor down.
5. De-activate the energy isolating device(s) so that compactor is isolated from the energy source(s).
 - a. Shut down all power sources.
 - b. Move the main disconnect lever to the OFF position.
6. Lock-out the energy isolating device(s) with assigned individual lock(s).
 - a. Padlock the disconnect lever with a keyed padlock and take the key with you.
 - b. Along with the padlock, place an appropriate, highly visible, warning tag on the disconnect lever. The tag should provide a warning such as:
"Danger: Do not operate equipment. Person working on equipment." or
"Warning: Do not energize without the permission of _____."
 - c. Place operating components in such a position so as not to be subject to possible free fall and/or install additional blocking devices to prevent this potential for any raised or elevated component.
7. Stored hydraulic energy must be removed from the compactor hydraulic circuit for complete Lock-Out and Tag-Out. Make sure that this energy has been relieved by manually depressing the solenoid valve pin located in the center of each coil end of the directional control valve.
8. After locking and tagging the compactor, ensure that the compactor is disconnected from the energy source by first checking that no personnel are exposed, then verify the isolation of the equipment by operating the push button or other normal operating control(s) or by testing to make certain the equipment will not operate. Try to start and operate the compactor (as outlined in the Operating Instructions) to make sure the Lock-Out and Tag-Out is effective. If the Lock-Out and Tag-Out is effective, remove the key from the key switch and take it with you.

5

LOCK-OUT/TAG-OUT INSTRUCTIONS (CONTINUED)

9. Before entering compactor perform hazard assessment for confined space requirements (hazardous fumes, dust, toxic material, or other hazards) per the OSHA confined space standard.

RESTORING SERVICE

When the servicing or maintenance is completed and the compactor is ready to return to normal operating condition, the following steps shall be taken:

1. Check the compactor and the immediate area around the compactor to ensure that nonessential items have been removed and that the compactor components, guards and covers are operationally intact.
2. Check the work area to ensure that all employees have been safely positioned or removed from any hazardous areas.
3. Verify that the controls are in neutral.
4. Remove the lock-out devices and re-energize the compactor.

NOTICE:

The removal of some forms of blocking may require re-energizing of the compactor before safe removal.

5. Notify affected employees that the servicing or maintenance is completed, and the compactor is ready for use.
6. Reassess area to determine all hazards are protected.

ELECTRICAL: The motor control panel contains high voltage components. Only authorized personnel should be allowed inside the control panel. Authorized personnel should be allowed inside the control panel only after the compactor has been locked out.



HYDRAULIC: Stored hydraulic energy must be removed from the compactor hydraulic circuit for a complete lock-out/tag-out. Make sure that this energy is relieved by manually depressing the solenoid valve pin located in the center of each coil end on the directional control valve.

Please Note: Some valves may have more than one coil and some power units may have more than one valve. All stored hydraulic energy must be removed. Disconnect the hydraulic quick disconnects that lead from the power unit to the compactor.

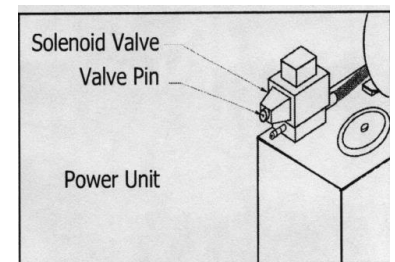

THE OWNER/EMPLOYER/OPERATOR IS RESPONSIBLE FOR HAVING A HAZARDOUS ENERGY CONTROL PROCEEDURE IN PLACE. THERE MAY ADDITIONAL LOCK-OUT/TAG-OUY PROCEDURES REQUIRED BEYOND THOSE LOCK-OUT/TAG-OUT PROCEDURES SET FORTH HEREIN.

PRE-OPERATION INSTRUCTIONS

Employers should allow only authorized and thoroughly trained personnel to operate this compactor.

This compactor is equipped with a key operated locking system. Keys should be in possession of only authorized personnel. Turn off and remove the key after use.

DANGER

ONLY TRAINED AND AUTHORIZED PERSONNEL SHOULD BE ALLOWED INSIDE PANEL BOX. The panel box contains high voltage components. See **Lock-Out/Tag-Out Instructions**.

WARNING

Do not operate compactor until operating instructions are thoroughly understood. Wear safety glasses and gloves when operating this equipment.

WARNING

Stay clear of all internal compactor parts and all moving external compactor parts when in operation. Failure to do so could result in serious personal injury or death!

WARNING

Never enter any part of compactor unless the disconnect switch has been turned off, padlocked, and all stored energy sources have been removed. See **Lock-Out/Tag-Out Instructions**.

WARNING

Do not remove access covers except for servicing. Only trained and authorized service personnel should be allowed to service this equipment. All access doors on the compactor body should always be secured in place when the unit is operating. See **Lock-Out/Tag-Out Instructions**.

WARNING

Before starting compactor, be sure no one is inside. Be certain that everyone is clear of all operation points and pinch point areas before starting.

WARNING

If the compactor is equipped with a security gate or doghouse with security door, be sure that the security gate or door is closed before the compactor is started.

NOTICE

Federal regulation prohibits the use of this equipment by anyone under 18 years of age.

OPERATIONAL SAFETY INSTRUCTIONS

- Federal regulation prohibits the use of this equipment by anyone under the age of 18.
 - Stay clear of all internal parts of the self-contained compactor/ container during operation! Failure to do so could result in serious injury or death!
 - Never enter any part of the compactor unless the disconnect switch has been locked-out and tagged-out! See lock-out/tag-out procedures on pages 4/5 of this manual. Before starting the compactor be sure no one is inside. Be certain that everyone is clear of all points of operation and pinch point areas before starting.
 - The owner(s) and/or employer(s) should allow only authorized and trained personnel to operate this compactor is equipped with a key operated locking system. The key(s) should be in possession of only authorized personnel.
 - Do not remove access cover except for servicing. Only authorized service personnel should be allowed inside. All access doors on the compactor body should be in place when the unit is operating. See lock-out/tag-out instructions on pages 4/5.
 - Only authorized personnel should be allowed inside the control panel. The motor Control panel contains high voltage components. See lock-out/tag-out instructions on pages 4/5.
 - If the compactor is equipped with a security gate or doghouse with security door be sure that the security gate/door is closed before the compactor is started.
 - NEVER** place hands or arms in the compactor while it is operating.
 - NEVER** disable any safety switch.
 - NEVER** overload the compaction chamber.
 - NEVER** place concrete, metal plates or castings, explosive materials, liquids, or hazardous waste in the compactor.
 - NEVER** climb in the compactor, nor perform any maintenance/repairs unless the power is disconnected and locked out/tagged out.
- NOTE:** Hydraulic oil is the primary power transmission on the compactor. Remember that hydraulic systems can remain pressurized even after the motor has stopped and/or the power has been disconnected. Refer to lock out/tag out procedures on pages 4/5.



OPERATIONAL CONTROL PENDANT DESCRIPTION

Typical control pendant. This may vary depending on the power unit manufacturer and model. This may vary from different power unit manufacturers. Please consult the manual provided in each power unit for specific details of your compactor operation.

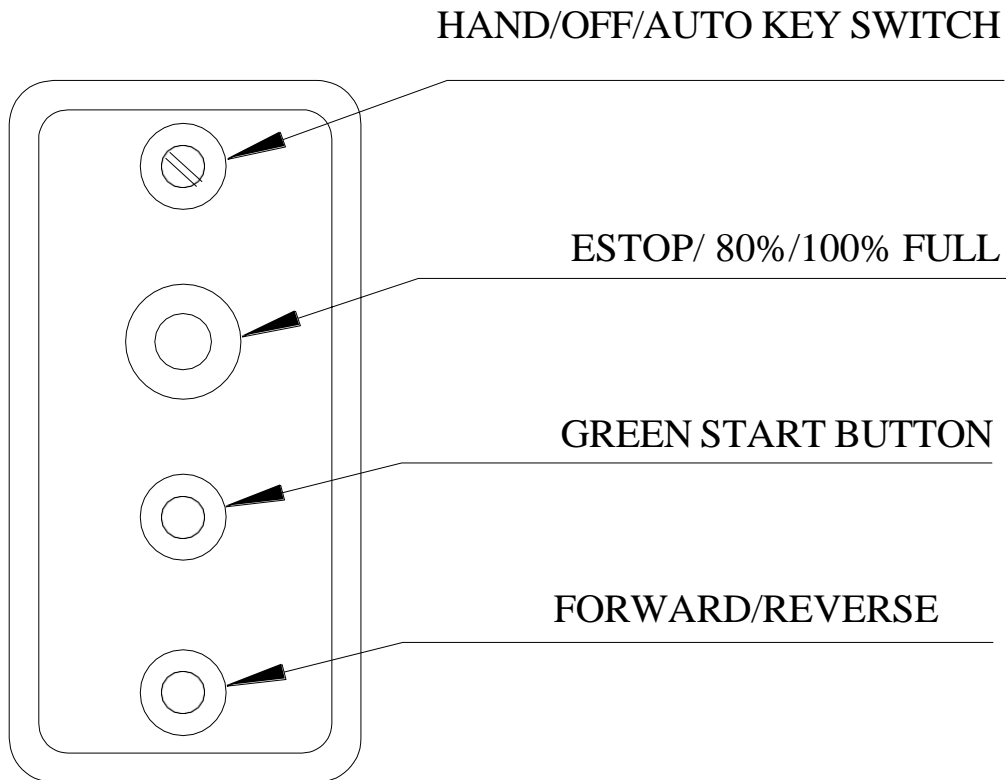

- 1) **KEYED HAND/OFF/AUTO SWITCH**- This switch controls the operation mode. By switching to hand mode, the operation can be controlled by the FOR/REV SWITCH only. By switching to the AUTO mode, the operation is controlled by the GREEN START button only. A key is required.
- 2) **EMERGENCY STOP/FULLNESS PUSH BUTTON**- When depressed this push button will stop all power operations of the compactor. Release of the ESTOP will cause the compactor to initiate the safety stop program upon first cycle of the GREEN START button. When the ESTOP is blinking the compactor is 80% full. When the ESTOP is solidly lit the compactor is 100% full and will shut down.
- 3) **START PUSH BUTTON**- This push button will only operate when the HAND/OFF/AUTO switch is in the AUTO mode. By depressing this push button, the pre-programmed will start and complete the number of cycles. If there is no safety switch installed on the compactor the unit will operate in the sustained manual pressure (push to run, dead man) mode.
- 4) **FOR/REV SWITCH**- This will operate when the HAND/OFF/AUTO switch is in HAND mode. This allows the operator to manually jog the ram forward or backward if needed.

OPTIONAL CONTROLS

These are the most common options provided for a unit. Other options are available upon request. Operation sequence may vary from different power unit manufacturers. Please consult the manual provided in each power unit for exact details of your compactor operation.

- 1) **SUSTAINED MANUAL PRESSURE CONTROL BUTTON-** (Hold -to-run, Release -to-stop/ Deadman). This requires the compactor operator to remain at the pendant station while the compactor is in use. Actuation requires depressing the START button. After the unit has started, if the START button is released the unit will stop.

- 2) **ADVANCED WARNING LIGHT-** When the ESTOP light starts flashing (ADVANCED WARNING) then there is 200 PSI left before the pressure switch is activated to shut the unit off and the container is full (unit will run while the light is flashing). When the light stays on continuously (CONTAINER FULL) the container is full and ready to be emptied before its next use. To deactivate the light, depress the EMERGENCY STOP button. The unit will not run when the light is on continuously.

- 3) **ACCESS INTERLOCK-** This option is required with all machines that run in automatic cycling mode. This is installed on doors, chutes or access gates. It prevents the unit from running if the door or gate is open. It will also stop the unit from running if the door or gate is opened during cycling.

- 4) **THERMOSTATICALLY CONTROLLED OIL HEATER-** This option is installed in the oil reservoir. This will heat the oil when the oil falls below the preset temperature.

- 5) **DOOR START-** This option will automatically start the unit after the access door or gate is opened and shut the preset number of times. The unit will complete its cycle and shut down automatically. A warning light and siren are required for this option.

- 6) **PHOTO EYE/SONIC SENSOR-** This option will automatically start the unit by sensing a buildup of discarded material in the charge chamber. The unit will complete its preprogrammed cycle and shut down. A warning light and siren are required.

OPERATING INSTRUCTIONS FOR STANDARD MODELS

Operation of compactor by trained and authorized personnel only! These operating instructions are not intended as a substitute for training and experience in proper use and safety procedure or protocol in operating this equipment.

- 1) Ensure the area around the compactor is clear and free of debris. Make sure there are no unauthorized person(s) in the area.
- 2) Next place material to be discarded into the compactor through the door/gate, close and lock it before starting the compactor.
- 3) Insert the key into the key switch and turn it to AUTO mode. Then press the green START button. The unit will first initiate the SAFETY STOP program. Then unit will reverse the ram fully and shut off. This will only happen upon the first start cycle. Then press the START button again and the unit will cycle the preset number of times determined by the PLC then it will stop.
- 4) Repeat as necessary after the compactor has stopped.
- 5) If at any time the door/gate is opened and the safety switch, contact has been broken the compactor will stop and will not start until the door/gate is closed and the safety switch contact has been restored. The START button must be pressed again to restart. Upon restart the SAFETY STOP program will initiate again. Then the unit will run the normal cycle program again.
- 6) When you have finished using the compactor return the key switch to the OFF position and remove the key. Ensure the door/gate is closed and locked.

IN CASE OF EMERGENCY

PUSH THE LARGE RED BUTTON TO STOP!!!

MANUAL OVERRIDE INSTRUCTIONS

If the ram has stopped in any position:

- To move the ram forward, turn the key switch to HAND and turn the switch to FOR.
- To move the ram rearward, turn the key switch to HAND and turn the switch to REV.

While the ram is moving:

- To reverse the ram while it's moving forward, press the EMERGENCY STOP button. Release the EMERGENCY STOP button and press the START button. The ram will reverse, and the unit will shut down. Or Press the EMERGENCY STOP button and turn the key switch to HAND mode. Turn the switch to REV.
- To cause the ram to move forward while it is moving rearward, press the EMERGENCY STOP button. Turn the key switch to HAND and turn the switch to FOR.

DECAL IMAGES



ICCLBL1000



CWL1000



SCC-001



SCC-002



SCC-003



SCC-004



SCC-005



SCC-006



SCC-007



SCC-008



SCC-011



SCC-012



SCC-013



SCC-014



SCC-015

DECAL PART NUMBERS

When your compactor leaves the factory several WARNING DECALS are installed for your protection. These labels are subject to wear due to the nature of the operation. THE FOLLOWING DECALS MUST BE MAINTAINED. Additional decals maybe purchased through INTERNATIONAL CONTAINER CO. by calling 413-538-9200. When ordering replacement decals, match the part numbers in the chart below to the drawings on the previous page.

PART NUMBER	DESCRIPTION
ICCLBL	INTERNATIONAL CONTAINER CO.
CWL1000	WARNING/ CAUTION
SCC-001	WARNING STAND CLEAR OF COMPACTOR
SCC-002	CONFINED SPACE
SCC-003	WARNING DO NOT REMOVE ACCESS COVERS
SCC-004	DO NOT REMOVE CONTAINER UNTIL REAR STOPS...
SCC-005	CAUTION WIPE OFF SEAL AFTER DUMPING
SCC-006	NOTICE FEDERAL REGULATION<NO 18 YEARS OLD
SCC-007	FIRE HOSE PORT
SCC-008	DANGER HAZARDOUS VOLTAGE
SCC-011	DANGER VOLTS
SCC-012	CAUTION DISCONNECT HOSES
SCC-013	WARNING KEEP OUT CRUSH/SHEAR HAZARD
SCC-014	WARNING CRUSH/SHEAR CLOSE GATE
SCC-015	CAUTION COMPACTOR STARTS AUTOMATICALLY

**QUANTITIES VARY DEPENDING ON EQUIPMENT AND OPTIONS.
SOME DECALS MAY BE INSTALLED ON THE POWER UNIT**

DECAL PLACEMENT ON COMPACTOR

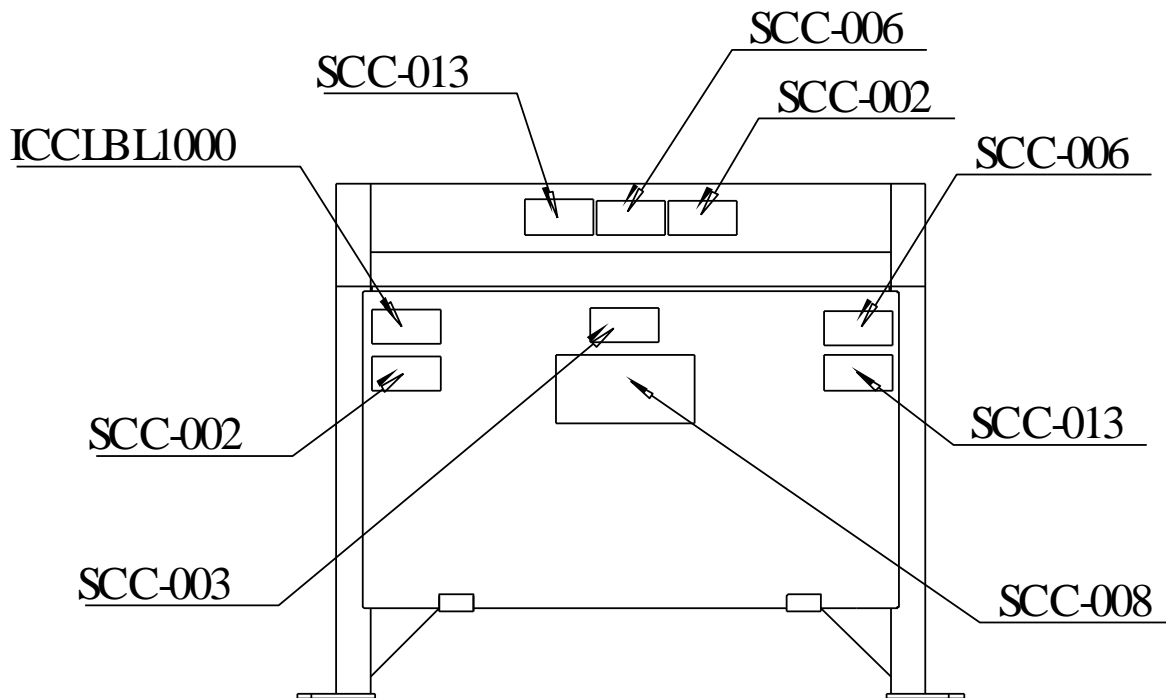
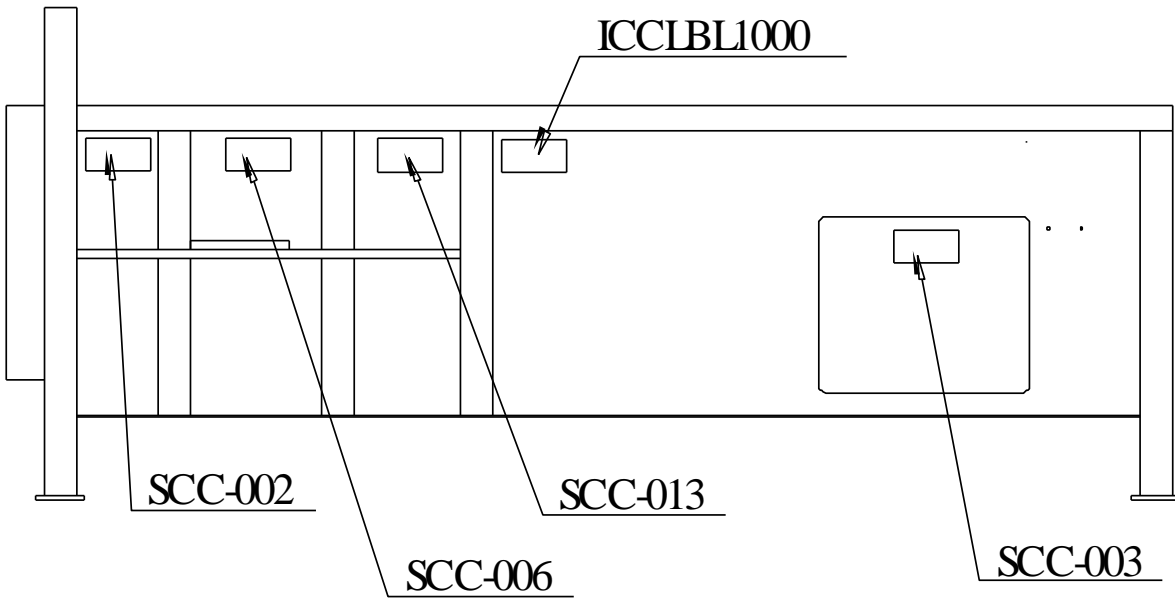

DECAL PLACEMENT ON LOADING OPTIONS

DOGHOUSE DOOR(S)

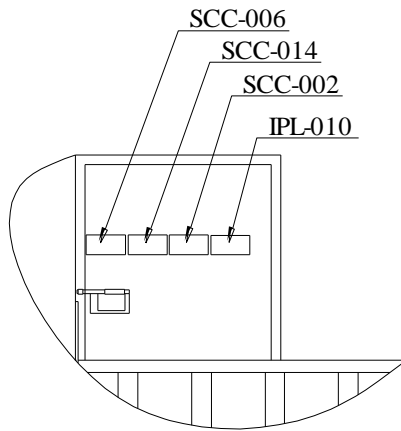

THRU-WALL SECURITY CUTE

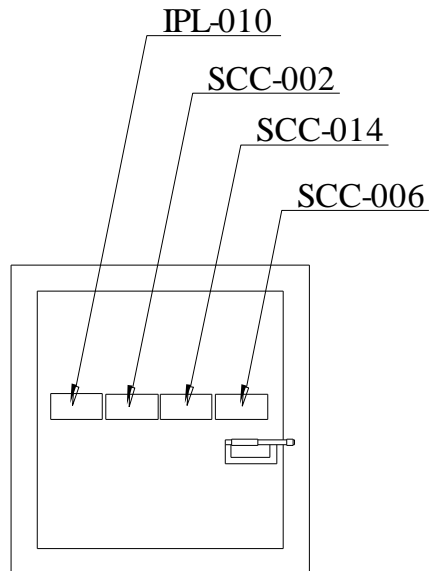

PERIODIC MAINTENANCE

WARNING: RAM SPEED ACCELERATES AS THE RAM RE-TRACTS!! NEVER ENTER ANY PART OF THE COMPACTOR OR CONTAINER UNTIL THE UNIT HAS BEEN LOCKED-OUT AND TAGGED-OUT!!!

MONTHLY

- 1) Check external hoses for chafing, rubbing, or other deterioration or damage.
- 2) Check for any obvious unsafe conditions in or around the compactor area.
- 3) Check oil level in hydraulic reservoir. Level should be $\frac{3}{4}$ of the sight gauge.
- 4) Check that all safety equipment is in good working order.
- 5) Clean or wash out debris behind the compactor ram.
- 6) Check functional operation of controls and options (stop button, timer, lights, etc.)

THREE MONTHS

- 1) Check hydraulic cylinder(s), internal hoses, and connections for leakage. Check hoses for chafing and wear.
- 2) Lubricate all grease fittings (hydraulic cylinder pins, ratchet binder, door hinges, wheels, nose rollers, etc.)

ANNUALLY

- 1) Lubricate electric motor per manufacturer's instructions.

OIL STRAINER

- 1) The oil strainer should be cleaned at regular yearly intervals.
- 2) The filter may be removed from the unit by disconnecting the union of the suction side of the pump. Remove the four bolts retaining the suction pipe gasket to cover plate and lift the filter from the reservoir.
- 3) Care should be exercised in cleaning the strainer to ensure the element is not torn. Clean the element with a soft brush and industrial solvent.
- 4) Replace and seal the filter after cleaning and tighten the union securely. Pump noise and 'CRACKLE' sound is most often caused by air entering the suction line. Tightening the suction fittings will usually eliminate this problem.

A STANDARD MEDIUM WEIGHT HYDRAULIC OIL IS RECOMMENDED FOR THIS SYSTEM

CYLINDER REMOVAL INSTRUCTIONS

- 1) Lock-out and tag-out the compactor per the procedure on pages 4/5.
- 2) Remove the access covers to the compactor.
- 3) Remove all hydraulic hoses attached to the cylinder.
- 4) Remove the cylinder pins.
- 5) Remove the cylinder.
- 6) To install the cylinder, reverse the steps.

Please consult the manual provided in the power unit for further maintenance information

TROUBLESHOOTING

This a general trouble shooting chart. For power unit trouble shooting please refer to the manual provided in each power unit.

PROBLEM	SOLUTION
MOTOR WILL NOT OPERATE	<ul style="list-style-type: none"> -Check EMERGENCY STOP BUTTON -Check security door/gate is shut -Check safety switch is plugged in -Check main breaker -Check fused disconnect -Refer to power unit manual
MOTOR RUNS BUT RAM WILL NOT MOVE	<ul style="list-style-type: none"> -Check hydraulic quick disconnects -Check hydraulic fluid level -Check motor rotation -Check directional valve for proper operation -Check for loose/broken fitting or hose -Check hydraulic cylinders for bypassing -Refer to power unit manual
COMPACTOR SHIFTS ERRATICALLY	<ul style="list-style-type: none"> -Check for proper system pressure -Check for proper pressure switch adjustment -Check directional valve operation -Check cylinder pins -Refer to power unit manual
COMPACTOR MAKES EXCESSIVE NOISE	<ul style="list-style-type: none"> -Check hydraulic fluid level -Check ram and guide lubrication -Check for water in hydraulic fluid -Check for air in hydraulic system -Check suction line components for tightness

INSTALLATION

CAUTION- Review this manual before making the installation. Study the jobsite and installation requirements to be certain all necessary safeguards and safety devices are provided to protect all personnel and equipment during the installation and as a completed system. Special attention is directed to the most current extract from the American National Standards Institute Z245.2. **These operating instructions are not intended as a substitute for training and experience in proper use and safety procedures or protocols in operating this equipment. International Container Co., LLC does not assume responsibility for the installation procedures of this equipment. Customer is responsible for ensuring compliance with all local, state, and federal laws concerning installation and use rest with the customer.**

CONCRETE PAD

- 1) Preferred dimensions of the concrete pad are 10'0" wide and a length 5'0" greater than the length of the compactor/container. It should be level and a minimum of 3000 PSI concrete steel reinforced 6" thick. It is preferred the concrete pad be flush with the surrounding ground level.
- 2) To provide accessibility, the concrete pad should be positioned to allow 2'0" between the machine and the building wall if installed parallel with the building. Allow a minimum of 45' of clear space from the end of the concrete pad for the container handling vehicle.

NOTE: The clearances given are MINIMUMS. Your installation may require greater clearances depending on the site and the handling equipment being used. Self-contained compactors should be anchored with $\frac{3}{4}$ " X 6" anchor bolts. These bolts should be concrete anchors or expansion type anchor bolts. Anchors are available from INTER-PAK COMPACTION, LLC.

CONTAINER GUIDES-If container guides are used the guides should be anchored with the same $\frac{3}{4}$ " X 6" anchor bolts used to secure the stationary compactor. It is best if these holes are drilled in the concrete after percolating the compactor and guides in their desired location. Drill holes and place anchor bolts in their location provided. When the compactor and guides have been placed in position and the anchor bolts have set, tighten all nuts securely.

DOCK INSTALLATION

If the appropriate accessories are ordered from INTER-PAK COMPACTION, LLC. the compactor/container will be furnished with either a four-sided hopper or a three-sided hopper with a hinged door or gate. THESE ACCESSORIES SHOULD NOT BE ALTERED AS THEY ARE MANUFACTURED IN ACCORDANCE WITH THOSE STANDARDS WHICH PREVAIL AT THE TIME OF MANUFACTURE!!!

If the compactor/container cannot be directly abutted to the dock or if there is any difference height between the compactor/container, an appropriately sturdy transition section should be provided by the customer and securely affixed to the dock. Along with the transition section a compactor/container guidance/stop mechanism should be installed to ensure that the unit does not bottom out against the transition section or the dock during placement (SEE ANSI Z245.2 SAFETY STANDARDS). Optional container guides with stops are available from INTER- PAK COMPACTION, LLC. and are recommended for proper placement of the compactor/container.

CHUTE FED INSTALLATION

Compactors installed in this arrangement are normally fed "THROUGH-THE-WALL". The lower edge of the access hole in the wall should be a MINIMUM OF 42" (and if possible, not more than 58") from the inside floor level. A security door (in accordance with local codes) should be installed in the wall opening. In absence of a local code, this door should be constructed of 3/16" thick steel, or steel hollow core design and be lockable from inside the building.

ALL DOORS/GATES SHOULD BE FITTED WITH MAGNETIC INTERLOCKS WHICH WILL IMMEDIATELY STOP THE COMPACTOR FROM RUNNING WHEN THE DOOR/GATE IS OPENED. The compactor should be manually started again.

DECALS

Be certain that the appropriate decals are always in their proper locations on the machine.

NOTE: Installation IS NOT complete until all decals are in place!!!

THRU THE WALL POWER UNIT INSTALLATION

If the power unit is to be mounted through-the-wall, the following list of materials and diagram is the suggested method.

LIST OF MATERIALS

ITEM#	QTY	DESCRIPTION
1	2	HYDRAULIC HIGH-PRESSURE HOSE (SIZED TO POWER UNIT) 36" LONG
2	2	SCHEDULE 80 PIPE (SIZED TO POWER UNIT) 18" LONG
3	2	HYDRAULIC HIGH-PRESSURE HOSE (SIZED TO POWER UNIT) 120" LONG
4	2	STEEL PLATE WITH HOLES FOR ITEM #2. 3/16" X 8" X 12"
5	2	FEMALE COUPLING SIZED TO FIT HOSE AND PIPE
6	2	QUICK DISCONNECT SET (MALE & FEMALE 2 SETS) 1/2" HOSE FOR RUNS 20' OR LESS. CONSULT FACTORY FOR LONGER

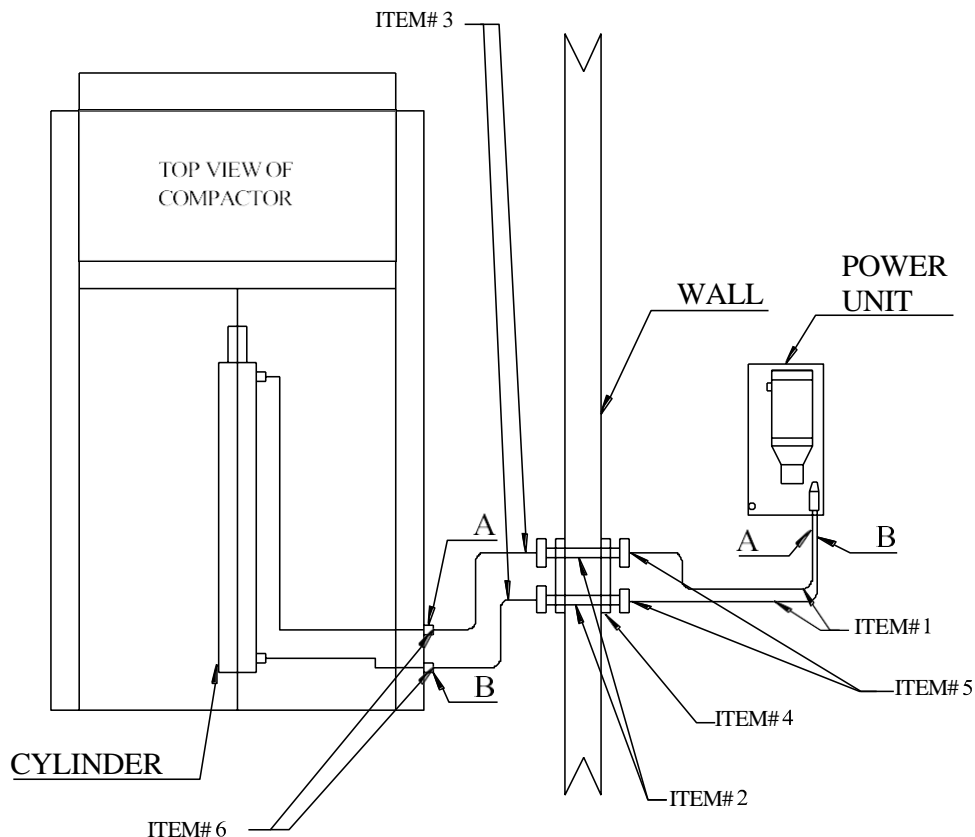

ELECTRICAL AND HYDRAULIC INSTALLATION



ONLY AUTHORIZED PERSONNEL SHOULD BE ALLOWED INSIDE THE CONTROL PANEL. The motor control panel contains high voltage components. See lock-out/tag-out procedures on pages 4/5.



ALL ELECTRICAL INSTALLATION MUST BE PERFORMED BY A LICENSED ELECTRICIAN

In addition to these instructions refer to the power unit manual for installation.

A lockable fused disconnect switch (customer furnished) must be installed and be within sight of the compactor motor control panel location, not to exceed 50'0" from the compactor. This fused disconnect switch should be sized in accordance with the compactor. Refer to power unit manual size chart.

CAUTION: All equipment should be grounded per National Electric Code and all applicable state and local requirements!!!

GROUNDING INSTRUCTIONS: This appliance must be connected to a grounded metal permanent wiring system, or an equipment grounding conductor must be run with the circuit conductors and connected to the equipment grounding terminal or lead on the appliance. If there is any doubt whether the equipment is properly grounded, a qualified electrician should be consulted.

REMOTE POWER UNIT INSTALLATION

- 1) The remote power unit should be installed and anchored as required by the customer. If the operator station is mounted in the face of the motor control panel, be certain these controls are located as to be in a convenient but not hazardous location to the customer.

CAUTION: Operator station must be located so that the **EMERGENCY STOP** button is readily accessible to the operator and within three (3) feet of the charging chamber access door. If installation requires the operator station to be in a more remote area, a second **EMERGENCY STOP** button must be added and installed in the manner described above.

- 2) For through-the-wall power unit installation see the diagram THROUGH-THE-WALL POWER UNIT INSTALLATION. Special care should be taken to protect the hoses from abrasive objects.

ELECTRICAL AND HYDRAULIC INSTALLATION

- 3) Connect the hydraulic hoses to the power unit, exercising care to follow port decals (A and B) on the packer and power unit. In the event the decals are obliterated, the hose leading from the rear of the cylinder should be installed in the B port of the aluminum valve sub plate. The hose leading from the rod end of the cylinder should be connected to the A port of the aluminum valve sub plate.

PUSH BUTTON CONTROL PENDANT

A remote operator station is furnished with all power units and is factory wired with 'sealtite' conduit. If it is necessary to disconnect it from the wires (to install the operator station inside the building) exercise care that the wires are reconnected as originally furnished by the factory (Check local codes to be certain 'sealtite' is acceptable).

CAUTION: The operator station must be located so that the **EMERGENCY STOP** button is readily accessible to the operator and within three (3) feet of the charging chamber access door. If the installation requires this operator station to be in a more remote area, a second **EMERGENCY STOP** button must be installed within three (3) feet of the access door.

WARNING: POWER UNIT MUST BE WIRED CORRECTLY FOR SUPPLY VOLTAGE!!!

All power units come factory wired for 460-VAC electrical service unless specified differently at the time the order is placed. Check that the power unit is wired correctly for the voltage provided at the installation site. If the voltage at the installation site is different from the factory wired power unit, the power unit must be changed to accept the voltage being supplied at the installation site. The motor must be changed over according to the wiring diagram supplied on the manufacturer's specification plate located on the motor. The control transformer wiring must also be changed over to accept the voltage being supplied at the installation site.

Once it is confirmed that the power unit wiring matches the supply voltage, run power lines between the fused disconnect switch (customer furnished) and the compactors motor control panel in accordance with all applicable electrical codes.

Refer to the manual provided in each power unit for specific installation procedures. Wiring diagrams for each power unit are provided in the power unit manual.

INSTALLATION START UP INSTRUCTIONS

IN CASE OF EMERGENCY PUSH THE LARGE RED BUTTON

- 1) With the ram fully retracted, check to be sure the oil reservoir is full to $\frac{3}{4}$ level on the sight gauge (Refer to the Maintenance section for hydraulic oil recommendations). The hydraulic system pressure has been factory set and the entire unit has been operated prior to shipment.
- 2) **CAUTION:** MAKE SURE ALL PERSONS AND MATERIAL ARE CLEAR OF THE CHARGE BOX AREA!!!
- 3) Jog the power unit using the FOR/REV switch to check the pump rotation.

CAUTION: IF THE PUMP ROTATES BACKWARD STOP IMMEDIATELY!!

The pump will be damaged if it is operated in reverse even for short periods. Reverse any two incoming power lines to change the motor/pump rotation.

- 4) Make sure all operators are trained in proper use of this equipment!!!

LEGAL PROVISIONS

Limitation on Liability

1. TO THE MAXIMUM EXTENT PERMITTED BY APPLICABLE LAW, THE RIGHTS AND REMEDIES SET FORTH HEREIN (WHETHER BY WAY OF DAMAGES, PAYMENT OR REIMBURSEMENT OF COSTS, PRICE REDUCTION, MAKE GOOD OR REMEDIATION, TERMINATION OR OTHERWISE) SHALL BE ITS SOLE AND EXCLUSIVE RIGHTS AND REMEDIES REGARDLESS OF THE EVENTS, CIRCUMSTANCES OR THEORY ON WHICH A CLAIM MAY BE BASED (INCLUDING TERMINATION, BREACH OF CONTRACT OR STATUTORY DUTY, NEGLIGENCE OR OTHER TORT, STRICT LIABILITY, INDEMNITY, RESCISSION / WITHDRAWAL OR OTHERWISE).

2. Notwithstanding any other provision to the contrary or the failure of the essential purpose of any exclusive or limited remedy, except only to the extent the exclusion of International Container Company's liability is limited by applicable law (in which circumstances International Container Company's liability shall be limited to the greatest extent permitted by applicable law):

INTERNATIONAL CONTAINER COMPANY SHALL IN NO CASE WHATSOEVER BE LIABLE FOR ANY (A) LOSS OF REVENUES OR PROFITS; LOSS OF OPPORTUNITY, PRODUCTION OR CONTRACTS; LOSS OF USE; STANDBY COSTS; LOSS OF OR DAMAGE TO UTILITIES OR PRODUCT; PLANT DOWNTIME OR DELAYS; LOSS OF GOODWILL; LIQUIDATED DAMAGES OR PENALTIES; CONTRACTUAL LIABILITY TOWARDS ANY THIRD PARTY; COSTS TO RECALL THE PRODUCT; ANY DAMAGES FINES OR PENALTIES; OR OTHERWISE FOR ANY FINANCIAL OR ECONOMIC LOSSES OR DAMAGES, AND IN EACH CASE IRRESPECTIVE WHETHER THE LOSSES OR DAMAGES IN QUESTION ARE DEEMED OR CLAIMED TO BE DIRECT, CONSEQUENTIAL, INDIRECT OR OTHERWISE, OR (B) FOR ANY CONSEQUENTIAL, INDIRECT, SPECIAL, INCIDENTAL, PUNITIVE OR EXEMPLARY, LOSSES OR DAMAGES HOWSOEVER CAUSED OR ARISING; OR (C) FOR ANY LOSS OR DAMAGE TO THE EXTENT ARISING OUT OF THE SOLE OR CONTRIBUTORY NEGLIGENCE OF YOU, YOUR EMPLOYEES OR AGENTS OR ANY THIRD PARTY.

3. Notwithstanding any other provision to the contrary or the failure of the essential purpose of any exclusive or limited remedy, except only to the extent the exclusion or limitation of International Container Company's liability is prohibited by applicable law (in which circumstances International Container Company's liability shall be limited to the greatest extent permitted by applicable law):

INTERNATIONAL CONTAINER COMPANY'S MAXIMUM AGGREGATE LIABILITY TO YOU OR ANYONE OPERATING THE [SC-200/SC-300/SC-400 STATIONARY COMPACTOR] SHALL IN NO CASE EXCEED THE GREATER OF THE PRICE PAID FOR OR REMAINING FAIR MARKET VALUE OF THE [SC-200/SC-300/SC-400 STATIONARY COMPACTOR], IRRESPECTIVE WHETHER SUCH LIABILITY ARISES BY WAY OF BREACH OF CONTRACT OR OF STATUTORY DUTY, NEGLIGENCE OR OTHER TORT, STRICT LIABILITY, INDEMNITY, CONTRACT PRICE REDUCTION OR REPAYMENT, TERMINATION, RESCISSION/WITHDRAWAL, MAKE GOOD OR REMEDIATION OR OTHERWISE.

4. No provision herein shall be deemed to expand or extend any provision of any other written document provided by International Container Company. Use of the [SC-200/SC-300/SC-400 STATIONARY COMPACTOR] is done at your sole risk and all procedures and policies shall be strictly followed. To the extent any waiver or disclaimer contained herein is deemed unlawful or unenforceable under applicable law, such waiver or disclaimer shall be deemed to be removed herefrom but only to such extent necessary to make such waiver or disclaimer compliant with applicable law.

Warranties; Disclaimers

1. International Container Company only provides the warranty set forth in its separate warranty policy and no other warranty. TO THE FULLEST EXTENT PERMITTED BY LAW, INTERNATIONAL CONTAINER COMPANY DISCLAIMS ALL REPRESENTATIONS AND WARRANTIES OF ANY KIND, WHETHER EXPRESS, IMPLIED OR STATUTORY, INCLUDING, BUT NOT LIMITED TO, THE IMPLIED WARRANTIES OF TITLE,

QUALITY, PERFORMANCE, MERCHANTABILITY, SUITABILITY, FITNESS FOR A PARTICULAR PURPOSE, ACCURACY AND NON-INFRINGEMENT RELATED TO OR ARISING FROM THE **[SC-200/SC-300/SC-400 STATIONARY COMPACTOR]** AS WELL AS WARRANTIES IMPLIED FROM ANY ALLEGED COURSE OF DEALING OR COURSE OF PERFORMANCE. INTERNATIONAL CONTAINER COMPANY DOES NOT WARRANT THAT THE **SC-200/SC-300/SC-400 STATIONARY COMPACTOR** WILL PROVIDE CONTINUOUS, PROMPT, SECURE, OR ERROR-FREE SERVICE. INTERNATIONAL CONTAINER COMPANY ASSUMES NO LIABILITY FOR ANY ERRORS OR OMISSIONS, INCLUDING THE INACCURACY OF CONTENT, OR FOR ANY DAMAGES OR LOSSES THAT YOU OR ANY THIRD-PARTY MAY INCUR AS A RESULT OF THE UNAVAILABILITY OR FAILURE OF **[SC-200/SC-300/SC-400 STATIONARY COMPACTOR]**.

2. International Container Company's responsibility under any warranty is subject to the condition that the underlying defect is not caused by one or more of the following: (i) use of non-original spare parts; (ii) use not in strict conformity with the specifications stated in International Container Company's written manuals and materials; (iii) any failure of upstream and/or downstream equipment necessary for the product to function properly; (iv) modifications without International Container Company's express prior written consent; (v) use of corrosive or abrasive substances; or (vi) the storage, handling, use, operation or maintenance of the product which is not in strict conformity with good engineering practice and any written requirements of International Container Company's written manuals and materials.

3. Any remedies set forth in the warranty policy shall be the sole and exclusive remedies in respect of any warranty obligation and International Container Company shall not be liable for any loss or damage caused by or resulting from any breach of warranty. If it is ultimately determined that this remedy fails of its essential purpose, then International Container Company's maximum liability is limited to the **[SC-200/SC-300/SC-400 STATIONARY COMPACTOR]**.

4. The expiration of any applicable warranty period shall, to the maximum extent permitted by applicable law, constitute conclusive evidence for all purposes and in all proceedings whatsoever between the parties that International Container Company has completed its obligations under or arising out of the warranty offered by International Container Company. After the expiration of any applicable warranty period, all claims of any nature whatsoever that may exist against International Container Company, whether known or not, under or arising out of the applicable warranty, and any right, cause of action and or remedy shall be deemed to be barred and extinguished.

Forum Selection Clause

1. The exclusive jurisdiction and the exclusive venue of the resolution of any dispute arising from the provisions of this Manual or use of the **[SC-200/SC-300/SC-400 STATIONARY COMPACTOR]** shall lie with the Superior Court of Massachusetts, Hampden County.